

 弘揚精密實業有限公司

HIACE ENGINE CO., LTD.

OWNER'S MANUAL

使用說明書

**EARTH AUGER 鑽孔機**

**AGV-280**

**AGH-350**

**CAUTION 注意**

- Before using our earth auger, please read this manual carefully to understand the proper use of your unit.  
使用本產品之前請務必先閱讀本使用說明書。
- Keep this manual handy. 本使用說明書請妥善保管。

## Contents 目錄

For safe operation 正確使用須知.....	2~3
Set up 安裝.....	3
Fuel 燃料.....	4
Use 操作.....	4~5
Maintenance 檢修.....	6
Storage 存放.....	7
Disposal 廢棄處置.....	7
Specifications 產品規格.....	7

### For safe operation 正確使用須知

1. Read this manual carefully until you completely understand and can follow all safety notes, precautions, and operating instructions before using of the unit.  
1. 使用前請務必先認真閱讀本使用說明書，將產品的性能及使用上的注意事項理解清楚。
2. Do not operate this tool when you are tired, ill, or under the influence of alcohol, drugs, or medication.  
2. 本產品如操作失誤將非常危險，故因疲勞等原因身體感到不適時，或由於服用了感冒藥或飲酒後致使判斷能力降低，難以準確進行操作時，請勿使用本產品。
3. When using the product, you should wear proper clothing and protective equipment that including Helmet, Ear protectors, Protection goggles or face protector, Thick work gloves, Non-slip-sole work boots.  
3. 操作機器時請務必穿戴適當保護裝備，如頭盔、耳塞或耳罩、防塵眼鏡或臉部防護罩、手套、防護鞋...等裝備。
4. Do not wear loose clothing, jewelry, short trousers, sandals, or go barefoot. Do not wear anything which might be caught by branches or moving parts of the unit. Secure hair so it is above shoulder length.  
4. 操作時請勿穿戴首飾或穿著褲腳寬大的褲子、短褲、涼鞋、草鞋或赤腳。
5. Never start or run the engine inside a closed room or building. Exhaust gases contain dangerous carbon monoxide.  
5. 引擎排出的氣體裡含有對人體有害的一氧化碳，請不要在室內，溫室內或隧道內等通風不好的地方使用本產品。
6. Before starting the engine, inspect the entire unit for loose fasteners and fuel leakage. Make sure that the drill bit is properly installed and securely fastened.  
6. 開始作業前，務必認真檢查機體各部，在確認沒有螺絲鬆動、漏油、損傷或變形等異常情況後方可開始作業。特別是鑽尾以及鑽尾連接部位更要仔細檢查。
7. Check the condition of working area to avoid any accident by hitting hidden obstacles such as stumps, stones, cans, or broken grass.  
7. 在開始作業前，需先弄清現場的狀況（地形、草的性質、障礙物的位置、周圍的危險度等）。清除可以移動的障礙物。
8. Fuel is highly flammable. Always keep open flames and sparks away from the unit and fuel depot. Do not smoke while refueling the unit or mixing fuel.  
8. 在加油和儲油地區必須嚴禁煙火。禁止叼著香煙作業、加油或混合燃料。
9. When refueling the unit, make sure to stop the engine and allow it to cool down. Wipe spilled fuel completely from the unit. Move at least 3 meters away from fueling site before starting the engine.  
9. 在加油之前必須確認引擎停止並冷卻，加油後將燃料容器密封，然後要在離開燃料容器 3 米以上的地方啟動引擎。
10. The area within a perimeter of 15 m (50 ft) of the person using the product should be considered a hazardous area into which no one should enter. If necessary, yellow warning rope, warning signs should be placed around the perimeter of the area. When work is to be performed simultaneously by two or more persons, care should also be taken to constantly look around or otherwise check for the presence and locations of other people working so as to maintain a distance between each person sufficient to ensure safety.  
10. 以作業者為中心，半徑 15 米 (50 呎) 以內為危險區域，為防止他人進入該區域，要用繩索圍起來或立起木牌以示警告，另外幾個人同時工作時，要不時地相互打招呼，並保持安全間隔。

## For safe operation 正確使用須知

11. Grip the handles firmly with both hands using your whole hand. Place your feet slightly apart (slightly further apart than the width of your shoulders) so that your weight is distributed evenly across both legs, and always be sure to maintain a steady, even posture while working.
12. Maintain the speed of the engine at the level required to perform drilling work, and never raise the speed of the engine above the level necessary.
13. After starting the engine, check to make sure that the drill stops moving when the throttle is moved fully back to its original position. If it continues to move even after the throttle has been moved fully back, turn off the engine and take the unit to your authorized HIACE servicing dealer for repair.
14. When the unit is turned off, make sure the drill attachment has stopped before the unit is set down.
15. Idea only for sinking holes and drill bit operation recommended by the manufacturer.
16. Drill only material recommended by the manufacturer. Do not let the drill bit contact material such as rocks, metal etc.
17. Instructions on stopping a drill bit. A drill bit can injure while it continues to spin after the engine is stopped or throttle control is released.
18. In the event that any part must be replaced or any maintenance or repair work not described in this manual must be performed, please contact a representative from the store nearest HIACE authorized servicing dealer for assistance.
19. Cover over the drill bit when transporting or storing the unit. Secure the unit before storage or transporting to prevent loss of fuel, damage or injury.
20. Use only for tasks explained in the instruction handbook.
11. 鑽孔作業時要保持穩定的姿勢。腳下較滑，難以保持穩定的作業姿態時，請勿使用本產品。
12. 引擎轉速請保持在作業需要的範圍之內，勿隨意提高引擎轉速。
13. 引擎啟動後，如加油柄在無效位置時，鑽尾仍旋轉不停，要馬上關掉引擎，將本產品交由 HIACE 所授權之服務業者進行檢修。
14. 將引擎關閉後，放置機器之前請務必確保鑽尾已經完全停止轉動。
15. 本產品是用於土壤地表之鑽孔作業為目的而設計的，請勿用於其它目的。
16. 請將本產品使用於製造者建議可接觸之材質上，請勿讓鑽尾接觸石頭或金屬等禁止接觸材質。
17. 中斷作業時，在剛停止引擎或扳回加油柄至無效位置時，高速運轉的鑽尾在完全停止轉動之前仍然具有殺傷力，請保持安全距離。
18. 本說明書上已記載維持產品性能所必要的檢修方法，如需要進行本說明書上未敘述之檢修時，請聯絡 HIACE 所授權之服務業者進行檢修。
19. 用汽車搬運時，請用繩索將機體牢固的固定在車槽內，以避免機體損壞或燃料外漏，請務必在鑽尾上安裝適當的防護罩具。因為危險，切勿用自行車或摩托車搬運。
20. 請確實依照本說明書的使用事項來操作此機器。

## Set up 安裝

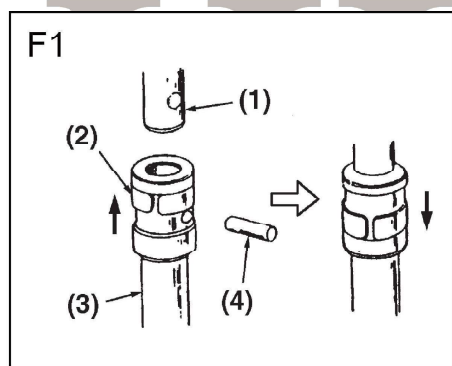

### ATTACHING THE DRILL BIT 安裝鑽尾

- Slide the ring clip and remove the lock pin from the drill bit.
  - Put the drill bit onto the auger output shaft and insert the lock pin. Cover it with the ring clip. (F1)
  - 滑動鑽尾上之鑽尾固定栓，取下插銷。
  - 鑽尾對準連接軸之圓孔部，將鑽尾推入連接軸，直到插銷可插入鑽尾及連接軸，再裝入鑽尾固定栓以固定鑽尾。(F1)
- (1) Output Shaft 連接軸
  - (2) Ring Clip 鑽尾固定栓
  - (3) Drill Bit 鑽尾
  - (4) Lock Pin 插銷

## Fuel 燃料

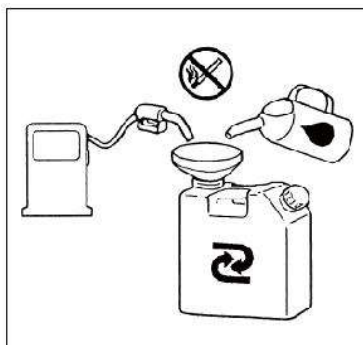

### WARNING 警告

- Keep open flames away from the area where fuel is handled or stored.
- Mix and store fuel only in an approved gasoline container.
- 在加油和儲油地區必須嚴禁煙火。
- 請使用適當的容器來混合或儲存燃料。

Mix a regular grade gasoline (leaded or unleaded, alcohol-free) and a quality-proven motor oil for air cooled 2-cycle gasoline engine use.

**Recommended mixing ratio : 25: 1**

建議使用市場上銷售的無鉛汽油及 2 行程 FC 或 FD 級機油。  
建議汽油及機油混合比例：25: 1

### NOTE 注意

Most engine troubles are caused, directly or indirectly, by the fuel used on the machine. Take special care not to mix a motor oil for 4-cycle engine use.

不能使用 4 衝程引擎，或水冷 2 衝程引擎機油，否則會造成火星塞堵塞，排氣口不通暢，或活塞環障礙。

Mix Chart 混合表

Gasoline (liters) 汽油(公升)	1	2	3	4	5
2-cycle oil (ml.) 二行程機油(毫升 ml.)	40	80	120	160	200

## Use 操作

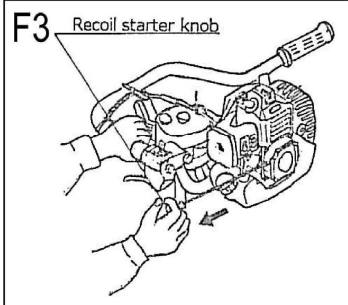
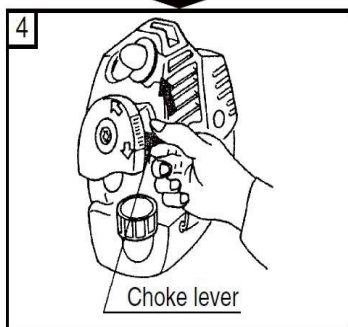
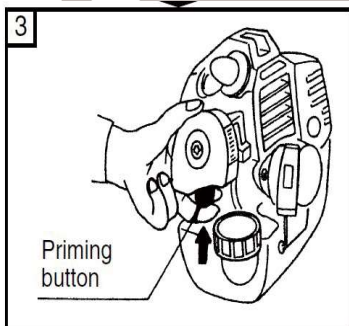

### STARTING THE ENGINE 啟動引擎

#### WARNING 警告

**Take care that the drill bit will start rotating upon the engine starts.**

啟動引擎時，鑽尾會開始旋轉，請注意安全。

1. Move the engine switch to the "ON" position.
  2. Set the throttle lever at the slow speed position.
  3. Push the priming button repeatedly with finger till it hits the top. (More than 10 times)
    - ◆ Pressing the priming button is necessary to prime the fuel to facilitate the start-up. Since any excess amount of primed fuel returns to the tank, there is no problem of over-priming. Prime the fuel rather more than sufficiently to avoid starting trouble.
  4. Turn the choke lever to the fully closed position.
    - ◆ When sufficient fuel is retained and the engine is warm, set the choke lever at the fully opened position.
  5. While holding down the engine firmly, grasp the recoil starter grip and pull vigorously.
  6. When the engine has started, return the choke lever gradually to the fully opened position.
    - ◆ If only exploding sounds are heard but it does not start, return the choke lever to the fully closed position
1. 將引擎開關設定至"ON"位置。
  2. 把油門開關設定在怠速位置。
  3. 按壓化油器下方的汽油泵數次，直到汽油泵內充滿汽油。
  4. 把風門開關移動到關閉位置。
  5. 將機器放置在平坦堅實的地方，確認鑽尾周圍沒有任何物品。牢牢握住機組，快速拉出啟動器拉繩。
  6. 在引擎啟動後，漸漸打開風門。讓引擎轉動 2~3 分鐘預熱後即可使用。

#### NOTE 注意

- When restarting immediately after stopping the engine, move the choke lever to the open position, move the throttle lever to the idling position.
- 在引擎停止後馬上重新啟動時，請把風門開關移到打開位置上，把油門開關設定在怠速位置。

## Use 操作

### ■ STOPPING ENGINE 停止引擎

1. Release the throttle lever.
  2. Move the engine switch to the "STOP" position.  
(Switch position may vary depending on the specifications. Refer to the instruction manual of driven equipment.)
- ◆ In chase of a push button type switch, keep pressing the push button till the engine stops completely.
  - ◆ Replenish the fuel before using up completely. It will make easier at the next starting.
  - ◆ When there is no subsequent work, drain the fuel from the fuel tank and restart the engine to use up the fuel remaining in the carburetor.

1. 轉動加油器到怠速位置上。
  2. 移動引擎開關至停止位置，直到引擎完全停止。關閉燃料開關。
- ◆ 如為按壓式啟動，請持續按壓，直到引擎完全停止。
  - ◆ 為使下次啟動更容易，建議燃料使用完畢再添加新的燃料。
  - ◆ 如有一段時間未使用到本機器，請將燃料全部洩出，再啟動引擎，直到其自然熄火停止為止。

### ■ ADJUSTING THROTTLE CABLE 調整加油線

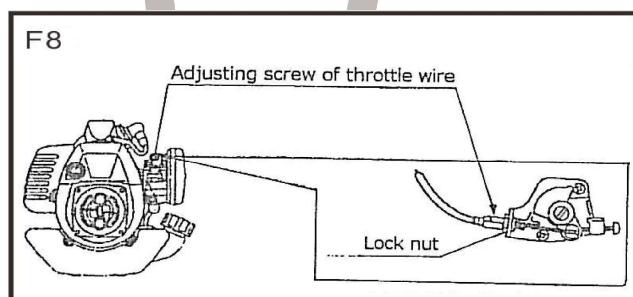

The normal play is 1 or 2mm when measured at the carburetor side end. Readjust with the cable adjuster as required.

卸下加油器，拉出加油線。從化油器一端丈量的話，一般為1~2毫米長。如果加油線過短或過長，請視需求調整加油線長度。

### ■ ADJUSTING IDLING SPEED 怠速調整螺絲

It is normal that the engine keeps running without the drill bit rotation, when the throttle lever is released. When the engine speed is too high or too slow, readjust the idle set screw.

這是用來調整將加油器扳至「啟動速度」位置時引擎轉數的螺絲。向右(順時針方向)旋轉時轉速便會上升，向左(逆時針方向)旋轉時轉速便會下降。如將加油器扳至「啟動速度」位置時，鑽尾轉動不停或引擎停止轉動時，可再次調整。

### ■ DRILLING WORK 鑽孔作業

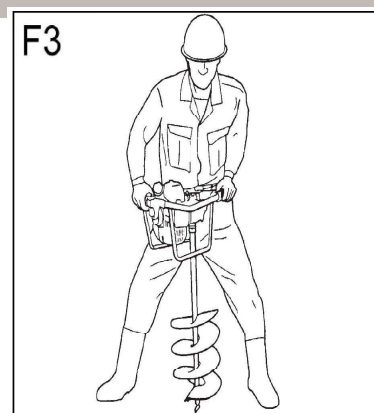

- ◆ Keep a firm grip of the auger at all times on a wide stance and by holding the handle with both hands.
- ◆ A reacting motion may occur on the auger when spinning drill has hit on stones or tree roots under the ground. Always hold the auger securely to control such motion.
- ◆ Start drilling with half-throttle, and gradually increase the engine speed so that the drill may get into the ground smoothly.
- ◆ When the drill has been caught in the ground and cannot be pulled out, stop the engine and rotate the auger counter-clockwise.
- ◆ 兩腳分開站好，保持安全平穩的姿勢，雙手抓緊把柄。
- ◆ 高速旋轉的鑽尾在碰到石塊、樹木、等堅硬的固定物體時，由於反作用力，發生反彈時，機體會突然出現劇烈抖動的現象，為保護操作者安全，操作時請務必保持雙手抓緊把柄。
- ◆ 開始使用時請以中速操作，再根據阻力大小適當提高引擎轉速。
- ◆ 當鑽尾陷入地面無法拉出時，停止引擎並以反方向(左旋)拉出機組。

### WARNING 警告

Before cleaning, inspecting, or repairing the unit, make sure that the engine has stopped and is cool.  
清理、檢查或修理機器前，先確認引擎已停止並冷卻。

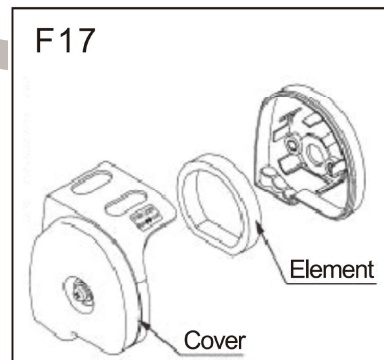

### AIR CLEANER 空氣濾清器

- Check and clean the filter element in warm, soapy water as required. Dry completely before installing. If the element is broken or shrunk, replace with a new one.
  - 請將空氣濾清器的外殼卸下來，清除內部的塵污。濾綿過髒的時候，請用溫水加中性洗滌劑清洗乾淨，待其完全乾燥後重新安裝再用。如濾綿變形或破損，請予以換新。
- (1) Element 濾綿 (2) Cover 空氣濾清器外蓋

### IMPORTANT 重要

A clogged air filter may increase fuel consumption while cutting down the engine power. And operate the earth auger without the air filter or with a deformed filter element will quickly ruin the engine.

如果空氣濾清器的濾氣海綿沾污過多而繼續使用時，會使引擎的機能降低。相反，如果不加墊海綿或者使用了變形或破損的海綿，會導致引擎內部異常消耗磨損。

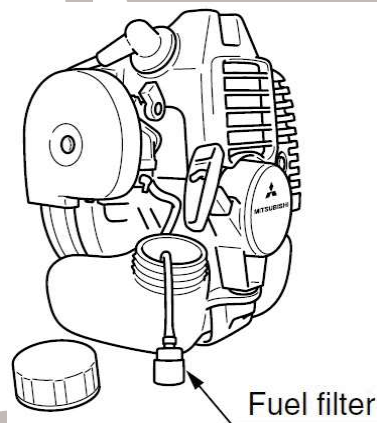

### FUEL FILTER 汽油濾清器

- After every 25 hours of operation, empty the fuel tank, detach the fuel filter from the tank, and remove all dirt. If the filter is too clogged, please replace it with a new one.
- 要從燃料箱的給油口對汽油濾清器進行檢查，如附污過多時，請將燃料箱的油全部倒出後，將汽油濾清器卸下並清除髒污，如汽油濾清器附污過多，請及時換新。

### IMPORTANT

- A clogged fuel filter may cause poor acceleration of the engine.
- 汽油濾清器因附污過多而不暢通時，會致使引擎轉速難以上升或轉速不穩定。

### SPARK PLUG 火星塞

Starting failure and mis-firing are often caused by a fouled spark plug. Periodically clean the spark plug and replace with a new one as required. The spark gap should be adjusted to 0.6 to 0.7 mm.

**REPLACEMENT PLUG IS A DENSO W-20MU / NGK BM6A.**

火星塞堵塞會引起引擎工作不良，請定期清理並適當更換火星塞。卸下火星塞，然後用鋼絲刷清除電極上附著的污垢。電極的間隙 0.6~0.7 mm 為妥。

更換火星塞時請使用指定產品 DENSO W-20MU / NGK BM6A。

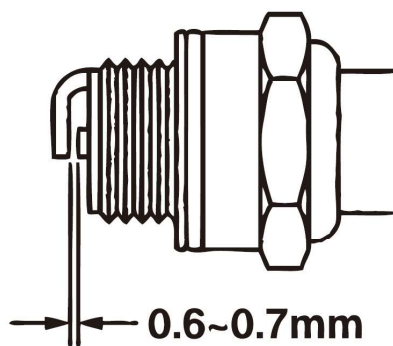

### IMPORTANT

- When mounting the plug cap, push it in securely.
- 裝回火星塞帽時，請確保安裝牢固。

## Storage 存放

### IMPORTANT 重要

#### MAINTENANCE BEFORE STORAGE 長期存放之前的檢修

Old fuel left in the carburetor may cause starting failure. When a series of operation finished, make sure to empty the fuel tank and run the engine until it uses all the fuel left in the fuel line and the carburetor. Store the unit indoor taking necessary measures for rust prevention.

將燃料箱裡的燃料全部倒出，並放鬆化油器的浮子室的排出螺絲或卸油閥以洩出燃料後，要啟動引擎，直到其自然熄火停止為止。

- Check all parts and the functions. If the failed or damaged parts have been found, replace them with new ones.
- 清潔機體的髒污，同時檢查各部位有無損傷或鬆動等。發現有異常時，應該徹底維修調整以備下次使用。

## Disposal 廢棄處置

- When disposing your machine, fuel or oil for the machine, be sure to allow your local regulations.
- 丟棄機器、燃料或潤滑油時，請依據並遵守當地相關法規處理。

## Specifications 產品規格

NAME 名稱		EARTH AUGER 鑽孔機			
TRANSMISSION TYPE 傳動形式		VERTICAL 直式		HORIZONTAL 橫式	
MODEL 型號		AGV-280-HT358L	AGV-280-TB43L	AGH-350-TB43L	AGH-350-TB52L
ENGINE MODEL 引擎型號		HT-358LT	TB-43LT	TB-43LT	TB-52LT
ENGINE 引擎	CYLINDER DIAMETER (mm) 汽缸直徑 (mm)	38	40	40	44
	PISTON STROKE (mm) 活塞行程 (mm)	30	34	34	34
	DISPLACEMENT (C.C.) 排氣量 (C.C.)	34	42.7	42.7	51.7
	MAX POWER 最大功率 (HP/7000RPM)	1.9	2.1	2.1	2.3
	CARBURETOR TYPE 化油器型式	DIAPHRAGM TYPE 膜片式			
	IGNITION SYSTEM 磁電機型式	Electronic CDI 電子 CDI			
	SPARK PLUG 火星塞型號	DENSO W-20MU / NGK BM6A			
	FUEL 燃油牌號	Lubricating oil mixed gasoline 90#以上汽油			
	MIXING RATE 燃油、潤滑油容積混合比	WITH 2 STROKE OIL LEVEL FC OR FD 25 : 1 使用市場上銷售的二行程 FC 或 FD 級機油 25 : 1			
	FUEL TANK CAPACITY(L) 燃油箱容積 (L)	1 LITER 公升			
STARTER 啟動方式	STARTER RECOIL 反沖啟動式				
CLUTCH TYPE 動力傳動方式		CENTRIFUGAL TYPE 自動遠心離合器、螺旋錐齒輪			
REDUCTION RATIO 減速比		28:1		35:1	