

HIACE ENGINE CO., LTD.

OWNER'S MANUAL 使用說明書

POWER SPRAYER 噴霧機

HT-708 HT-747

HT-768 HT-767

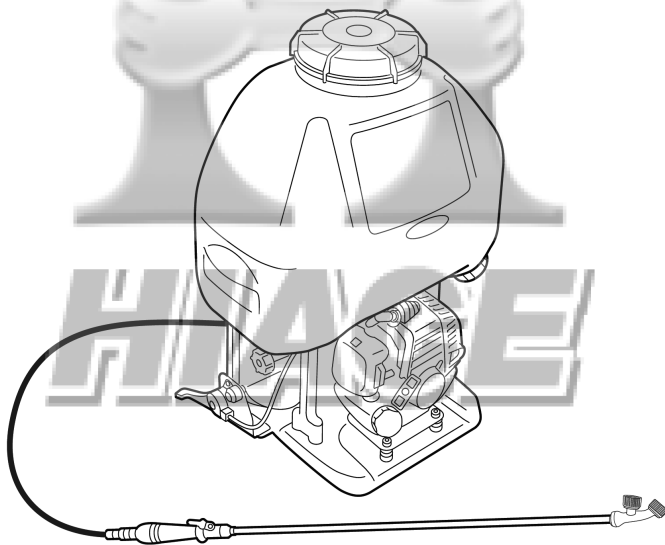

CAUTION 注意

● Before using our brush cutter, please read this manual carefully to understand the proper use of your unit.

使用本產品之前請務必先閱讀本使用說明書。

● Keep this manual handy. 本使用說明書請妥善保管。

Contents 目錄

For safe operation 正確使用須知.....	2~3
Parts Location 各部位名稱.....	3
Set up 安裝.....	4
Fuel 燃料.....	5
Chemical Filling 藥液添加.....	5
Use 操作.....	6~8
Maintenance 檢修.....	9~10
Storage 存放.....	10
Disposal 廢棄處置.....	10
Specifications 產品規格.....	11

For safe operation 正確使用須知

1. Read this manual carefully until you completely understand and can follow all safety notes, precautions, and operating instructions before using of the unit.
1. 使用前請務必先認真閱讀本使用說明書，將產品的性能及使用上的注意事項理解清楚。
2. Do not operate this tool when you are tired, ill, or under the influence of alcohol, drugs, or medication.
2. 本產品如操作失誤將非常危險，故因疲勞等原因身體感到不適時，或由於服用了感冒藥或飲酒後致使判斷能力降低，難以準確進行操作時，請勿使用本產品。
3. When using the product, you should wear proper clothing and protective equipment that including Helmet, Ear protectors, Protection goggles or face protector, Thick work gloves, Non-slip-sole work boots.
3. 操作機器時請務必穿戴適當保護裝備，如頭盔、耳塞或耳罩、防塵眼鏡或臉部防護罩、手套、防護鞋...等裝備。
4. Do not wear loose clothing, jewelry, short trousers, sandals, or go barefoot. Do not wear anything which might be caught by branches or moving parts of the unit. Secure hair so it is above shoulder length.
4. 操作時請勿穿戴首飾或穿著褲腳寬大的褲子、短褲、涼鞋、單鞋或赤腳。
5. Never start or run the engine inside a closed room or building. Exhaust gases contain dangerous carbon monoxide.
5. 引擎排出的氣體裡含有對人體有害的一氧化碳，請不要在室內、溫室內或隧道內等通風不好的地方使用本產品。
6. Before starting the engine, inspect the entire unit for loose fasteners and fuel leakage.
6. 開始作業前，務必認真檢查機體各部，在確認沒有螺絲鬆動、漏油、損傷或變形等異常情況後方可開始作業。
7. After starting the engine, check to make sure that the spray gun stops spraying when the throttle is moved fully back to its original position. If it continues to move even after the throttle has been moved fully back, turn off the engine and take the unit to your authorized HIACE servicing dealer for repair.
7. 引擎啟動後，如加油柄在無效位置時，噴槍仍不停止噴灑，要馬上關掉引擎，將本產品交由 HIACE 所授權之服務業者進行檢修。
8. Fuel is highly flammable. Always keep open flames and sparks away from the unit and fuel depot. Do not smoke while refueling the unit or mixing fuel.
8. 在加油和儲油地區必須嚴禁煙火。禁止叨著香煙作業、加油或混合燃料。
9. When refueling the unit, make sure to stop the engine and allow it to cool down. Wipe spilled fuel completely from the unit. Move at least 3 meters away from fueling site before starting the engine.
9. 在加油之前必須確認引擎停止並冷卻，加油後將燃料容器密封，然後要在離開燃料容器 3 米以上的地方啟動引擎。
10. This product has been designed mainly for the purpose of spraying pest control chemicals and weedkillers. Please do not use it for any other purpose, as this may cause unforeseen accidents.
10. 本產品是用於保護農作物及植物之藥液噴灑作業為目的而設計的，請勿用於其它目的。

For safe operation 正確使用須知

11. Maintain the speed of the engine at the level required to perform spraying work, and never raise the speed of the engine above the level necessary.
12. After chemical refilling, firmly tighten the tank cap. If not fully tightened the cap may become loose during spraying, with the risk of physical exposure to the chemicals.
13. Do not allow children, animals, etc., to enter the chemical spraying area. When work is to be performed simultaneously by two or more persons, care should also be taken to constantly look around or otherwise check for the presence and locations of other people working so as to maintain a distance between each person sufficient to ensure safety.
14. While spraying please hold the grip firmly at all times and be careful not to point the nozzle in the direction of people or animals.
15. Do not touch the spark plugs while the engine is running, as you may get an electric shock.
16. In the event that any part must be replaced or any maintenance or repair work not described in this manual must be performed, please contact a representative from the store nearest HIACE authorized servicing dealer for assistance.
17. Secure the unit before storage or transporting to prevent loss of fuel, damage or injury. Do not transport the sprayer while it has chemicals or fuel in the tank, as these could leak out as a result of impact during transportation.
18. Use only for tasks explained in the instruction handbook.
11. 引擎轉速請保持在作業需要的範圍之內，勿隨意提高引擎轉速。
12. 填充藥液後，請務必確保藥桶蓋已旋緊蓋好，以免藥液漏出。
13. 請勿讓孩童、動物等進入噴灑範圍區域。另外幾個人同時工作時，要不時地相互打招呼，並保持安全間隔。
14. 噴灑作業時請握緊握把，切勿將噴嘴面對他人或動物。
15. 引擎啟動時，請勿觸碰火星塞，以免遭受電擊。
16. 本說明書上已記載維持產品性能所必要的檢修方法，如需要進行本說明書上未敘述之檢修時，請聯絡 HIACE 所授權之服務業者進行檢修。
17. 用汽車搬運時，請用繩索將機體牢固的固定在車槽內，以避免機體損壞或燃料外漏。藥桶或油箱內裝有藥液或燃料時切勿搬運機體，避免藥液或燃料於運送途中漏出。
18. 請確實依照本說明書的使用事項來操作此機器。

Parts Location 各部位名稱

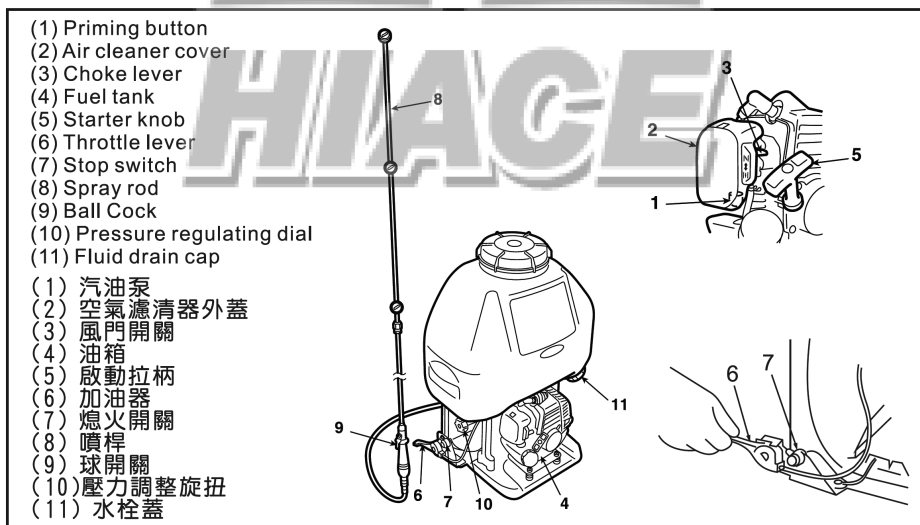

Set up 安裝

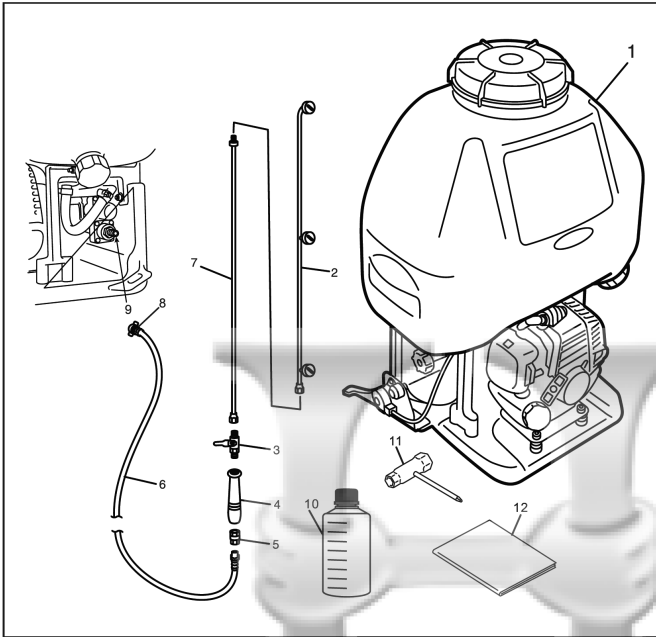

- (1) Unit
- (2) Spray Rod
- (3) Ball Cock
- (4) Filter Handle
- (5) Roller
- (6) High Pressure Hose
- (7) Rod
- (8) Connecting Nut
- (9) Pump Spray Outlet
- (10) 1L Fuel Premix Canister
- (11) 17*19 Combi. Box Wrench
- (12) Owner's manual

- (1) 機體
- (2) 噴桿
- (3) 球開關
- (4) 握把式過濾管
- (5) 活動頭
- (6) 高壓管
- (7) 白鐵直桿
- (8) 連接螺帽
- (9) 泵浦出水室
- (10) 1L油料混合筒
- (11) 17*19 火星塞板手
- (12) 操作說明書

CONNECTING THE HIGH PRESSURE HOSE AND SPRAY ROD 連接高壓管及噴桿

1. Connect the High Pressure Hose (6) to the Pump Spray Outlet (9) and firmly tighten the Connecting Nut (8).
2. Tightly screw the Roller (5) onto the High Pressure Hose (6).
3. Tightly screw the Filter Handle (4) onto the Roller (5).
4. Tightly screw the Ball Cock (3) onto the Filter Handle (4).
5. Tightly screw the Rod (7) onto the Ball Cock (3).
6. Tightly screw the Spray Rod (2) onto the Rod (7).

1. 連接高壓管(6)至泵浦出水口(9)，並鎖緊蝶型連接螺帽(8)。
2. 連接高壓管(6)至活動頭(5)一端。
3. 連接握把式過濾管(4)至活動頭(5)另一端。
4. 將球開關(3)裝至握把式過濾管(4)另一端。
5. 連接白鐵直桿(7)至球開關(3)另一端。
6. 連接噴桿(2)和白鐵直桿(7)。

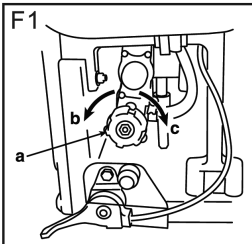

ADJUSTING SPRAY PRESSURE 調整操作壓力

● The pump has a pressure regulating dial (a) to change spray pressure. Set the pressure at a level appropriate to the spray conditions. The maximum operating pressure is 35kg/cm³. (F1)

1. Turn in a clockwise direction to increase the pressure. (c)
2. Turn in a counterclockwise direction to decrease the pressure. (b)

● 泵浦附有簡易調節壓力旋鈕(a)，請視情況調整壓力至合適需求，最大操作壓力為35kg/cm³。(F1)

1. 順時鐘(右旋)旋轉以增加操作壓力。(c)
2. 逆時鐘(左旋)旋轉以降低操作壓力。(b)

Fuel 燃料

WARNING 警告

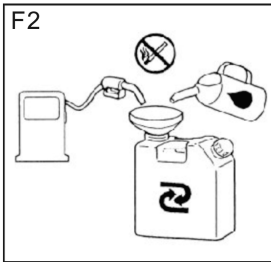

NOTE 注意

- Keep open flames away from the area where fuel is handled or stored.
- Mix and store fuel only in an approved gasoline container.
- 在加油和儲油地區必須嚴禁煙火。
- 請使用適當的容器來混合或儲存燃料。

Mix a regular grade gasoline (leaded or unleaded, alcohol-free) and a quality-proven motor oil for air cooled 2-cycle gasoline engine use. (F2)
建議使用市場上銷售的無鉛汽油及 2 行程 FC 或 FD 級機油。(F2)

Recommended mixing ratio 建議汽油及機油混合比例：25: 1

Mix Chart 混合表					
Gasoline (liters) 汽油(公升)	1	2	3	4	5
2-cycle oil (ml.) 二行程機油(毫升 ml.)	40	80	120	160	200

Most engine troubles are caused, directly or indirectly, by the fuel used on the machine. Take special care not to mix a motor oil for 4-cycle engine use.

不能使用 4 衝程引擎，或水冷 2 衝程引擎機油，否則會造成火星塞堵塞，排氣口不通暢，或活塞環障礙。

Chemical Filling 藥液添加

WARNING 警告

- Chemical substances should be handled correctly, observing the precautions marked on the container. Some chemicals are extremely hazardous to humans and animals, and handling errors can cause serious poisoning or even fatal accidents.
- When not in use, chemical substance containers should be stored separately from other containers out of the reach of children.
- 藥液含有化學物質，需小心處理，請依照藥液包裝外指示使用，尤其是對人體或動物有害的物質更要特別小心，以避免發生致命意外。
- 不需使用藥液時，需將藥液儲存在適當的容器及地點。

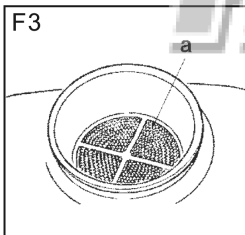

1. Use a bucket or other suitable container and dilute the chemical to the requisite strength.
2. Place the sprayer on an even and stable surface and remove the chemical tank cap.
3. Fill the tank by passing chemical through the strainer (a). (F3)
4. When filling is complete, firmly tighten the cap.

1. 使用適當的容器稀釋藥液至需求條件比例。
2. 放置噴霧機於平坦穩定的表面上，取下水桶蓋。
3. 透過水桶過濾網(a)，倒入已稀釋之藥液至水桶內。(F3)
4. 添加完成後，請旋緊水桶蓋。

NOTE 注意

Do not fill the chemical tank with undiluted fluid. This could cause the gasket and valves to lose their durability.
切勿將未經稀釋的藥液倒入水桶內使用，否則將影響墊片及活門之使用壽命。

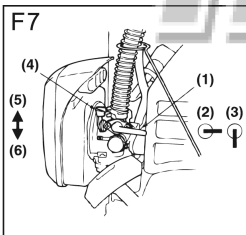
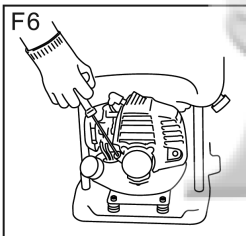
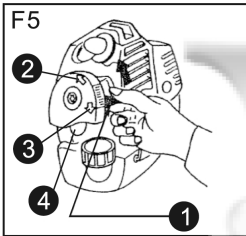
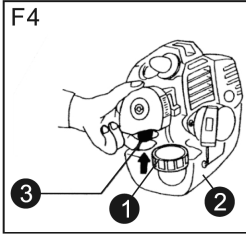

■ STARTING THE ENGINE 啟動引擎

WARNING 警告

Before starting the engine, make sure that the spray lever (Ball Cock) is completely returned. Starting with the spray lever still pulled out is dangerous, as chemical fluid may spray out of the nozzle as soon as the starts.

啟動引擎之前，務必確定球閘開關已關閉，否則引擎一旦啟動，噴嘴可能即會噴出藥液。

Diaphragm Engine 膜片式引擎:

1. Move the engine switch to the "ON" position.
2. Set the throttle lever at the slow speed position.
3. Push the priming button repeatedly with finger till it hits the top. (More than 10 times)

◆ Pressing the priming button is necessary to prime the fuel to facilitate the start-up. Since any excess amount of primed fuel returns to the tank, there is no problem of over-priming. Prime the fuel rather more than sufficiently to avoid starting trouble.

4. Turn the choke lever to the fully closed position.
- ◆ When sufficient fuel is retained and the engine is warm, set the choke lever at the fully opened position.
5. Place the sprayer on an even and stable surface. While holding down the engine firmly, grasp the recoil starter grip and pull vigorously.
6. When the engine has started, return the choke lever gradually to the fully opened position. Allow the engine to run for 2 to 3 minutes to warm up.

◆ If only exploding sounds are heard but it does not start, return the choke lever to the fully closed position

1. 將引擎開關設定至 "ON" 位置。
2. 把油門開關設定在怠速位置。
3. 按壓化油器下方的汽油泵數次，直到汽油泵內充滿汽油。
4. 把風門開關移動到關閉位置。

◆ 如果在引擎停止後不久即要再重啟動，油箱內有油且引擎仍是溫暖的，則將風門開關移到全開位置。

5. 將機器放置在平坦堅實的地方，確認周圍沒有任何物品。然後左手壓住水桶，用右手快速拉出啟動器拉繩。

6. 在引擎啟動後，漸漸打開風門。讓引擎轉動 2-3 分鐘預熱後即可使用。

◆ 如只聽到爆發的聲音但引擎未啟動，將風門開關移動到關閉位置。

Float Engine 浮筒式引擎:

1. Open the fuel tank cock.
2. Move the choke lever to the closed position. (F7)

- | | |
|--------------------|----------------------|
| (1) Fuel cock 燃料開關 | (4) Choke lever 阻風拉柄 |
| (2) Close 關閉 | (5) Close 關閉 |
| (3) Open 打開 | (6) Open 打開 |

3. Set the throttle lever to the idling position
4. Place the sprayer on an even and stable surface. While holdin gdown the engine firmly, grasp the recoil starter grip and pull vigorously.
5. When the engine has started, return the choke lever gradually to the fully opened position. Allow the engine to run for 2 to 3 minutes to warm up.

1. 打開燃料箱開關。

2. 把風門開關移動到關閉位置。(F7)

3. 把油門開關設定在怠速位置。
4. 將機器放置在平坦堅實的地方，確認周圍沒有任何物品。然後左手壓住水桶，用右手快速拉出啟動器拉繩。

5. 在引擎啟動後，漸漸打開風門。讓引擎轉動 2-3 分鐘預熱後即可使用。

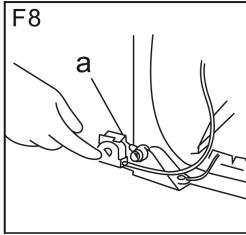

■ STOPPING ENGINE 停止引擎

1. Lower the throttle lever fully and cool the engine down for 1-2 minutes at low speed.
 2. Hold down stop switch (a) on the left side of the sprayer frame until the engine has come to a complete stop. (F8)
(Switch position may vary depending on the specifications. Refer to the instruction manual of driven equipment.)
- ◆ Replenish the fuel before using up completely. It will make easier at the next starting.
 - ◆ When there is no subsequent work, drain the fuel from the fuel tank and restart the engine to use up the fuel remaining in the carburetor.

1. 轉動加油器到怠速位置上，讓引擎降溫持續1至2分鐘。
 2. 按壓噴霧機左方之停止開關(a)，直到引擎完全停止。關閉燃料開關。(F8)
- ◆ 為使下次啓動更容易，建議燃料使用完畢再添加新的燃料。
 - ◆ 如有一段時間未使用到本機器，請將燃料全部洩出，再啓動引擎，直到其自然熄火停止為止。

■ ADJUSTING IDLING SPEED 怠速調整螺絲

It is normal that the engine keeps running when the throttle lever is released.

When the engine speed is too high or too slow, readjust the idle set screw.(F9 & F10)

這是用來調整將加油器扳至「啓動速度」位置時引擎轉數的螺絲。向右(順時針方向)旋轉時轉速便會上升，向左(逆時針方向)旋轉時轉速便會下降。如將加油器扳至「啓動速度」位置時，引擎停止轉動，可再次調整。(F9 & F10)

(Diaphragm Engine 膜片式引擎)

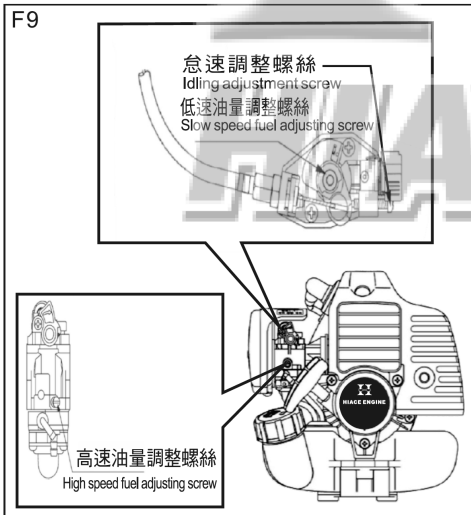

(Float Engine 浮筒式引擎)

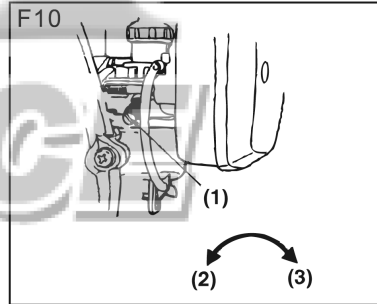

- (1) Idling adjustment screw 怠速調整螺絲
- (2) Rotation increases 轉速增加
- (3) Rotation decreases 轉速降低

Use 操作

■ ADJUSTING THROTTLE CABLE 調整加油線

The normal play is 1 or 2mm when measured at the carburetor side end. Readjust with the cable adjuster as required. (F11 & F12)

卸下加油器，拉出加油線。從化油器一端丈量的話，一般為1~2毫米長。如果加油線過短或過長，請視需求調整加油線長度。(F11 & F12)

(Diaphragm Engine 膜片式引擎)

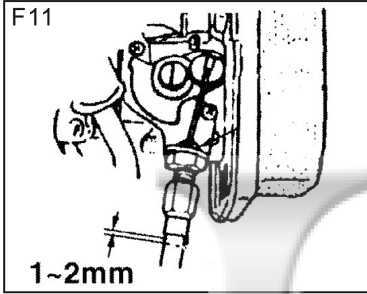

(Float Engine 浮筒式引擎)

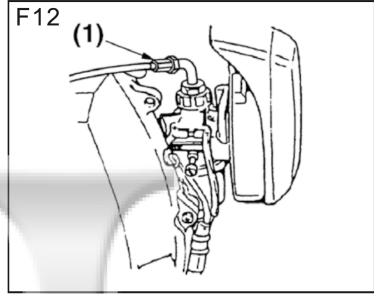

■ SPRAYING WORK 噴灑藥液作業

WARNING 警告

If the chemical tank becomes empty while spraying, reduce the engine to low speed immediately. Empty running of the engine may cause the spray pump to break.

若噴灑作業時發現水桶內藥液已快用盡，請立即降低速度，以免導致泵浦損壞。

F13

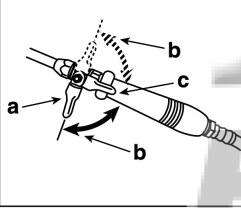

● Start the engine, and lift the sprayer onto your back. Adjust the carrying band to a suitable length for carrying.

● Increase the engine speed, and open the spray cock (Ball Cock) (c). Chemical fluid starts to spray out from the nozzle in the form of mist.

● When stopping work, close the spray cock (Ball Cock) (b) fully and reduce the engine speed. (F13)

● 啟動引擎，將噴霧機背在後背上。視需求調整背帶長度。

● 調整引擎速度，打開球開關(c)，藥液即開始由噴嘴呈霧狀噴出。

● 要停止作業時，完全關閉球開關(b)，且降低引擎速度。(F13)

a. Ball Cock球開關 b. Close關閉球開關 c. Open開啓球開關

F14

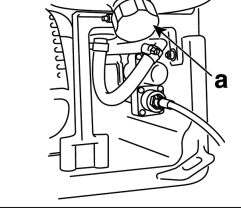

■ CLEANING AFTER COMPLETION OF SPRAYING

結束噴灑作業後之清潔作業

(a) Loosen the fluid drain cap (a), transfer the chemical fluid left inside the tank into a suitable container, and process appropriately with all due consideration to safety. (F14)

(b) Pour about 5 liters of clean water into the chemical tank, spray through the nozzle for 2-3 minutes, and drain the water left inside the tank.

(a) 開啓水栓蓋(a)，洩出水桶內的藥液至適當容器，洩出過程請務必注意安全。(F14)

(b) 倒入約5公升乾淨的水至水桶內，經由噴嘴將水噴出持續2至3分鐘，接著倒出水桶內的水。

● For your health and to prevent the risk from vibration, refrain from working for a long time at the cold temperature. 請避免在低溫環境下長時間操作機器，以確保操作者的健康及安全。

Maintenance 檢修

WARNING 警告

Before cleaning, inspecting, or repairing the unit, make sure that the engine has stopped and is cool.
清理、檢查或修理機器前，先確認引擎已停止並冷卻。

(Diaphragm Engine 膜片式引擎)

F15

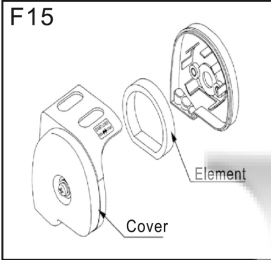

■ AIR CLEANER 空氣濾清器

- Check and clean the filter element in warm, soapy water as required. Dry completely before installing. If the element is broken or shrunk, replace with a new one. (F15 & F16)
- 請將空氣濾清器的外殼卸下來，清除內部的塵污。濾綿過髒的時候，請用溫水加中性洗滌劑清洗乾淨，待其完全乾燥後重新安裝再用。如濾綿變形或破損，請予以換新。(F15 & F16)

(Float Engine 浮筒式引擎)

F16

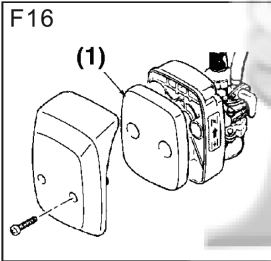

IMPORTANT 重要

- A clogged air filter may increase fuel consumption while cutting down the engine power. And operate the engine without the air filter or with a deformed filter element will quickly ruin the engine.
- 如果空氣濾清器的濾氣海綿沾污過多而繼續使用時，會使引擎的機能降低。相反，如果不加墊海綿或者使用了變形或破損的海綿，會導致引擎內部異常消耗磨損。

F17

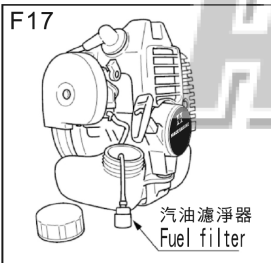

■ FUEL FILTER 汽油濾清器

- After every 25 hours of operation, empty the fuel tank, detach the fuel filter from the tank, and remove all dirt. If the filter is too clogged, please replace it with a new one. (F17)
- 要從燃料箱的給油口對汽油濾清器進行檢查，如附污過多時，請將燃料箱的油全部倒出後，將汽油濾清器卸下並清除髒污，如汽油濾清器附污過多，請及時換新。(F17)

IMPORTANT

- A clogged fuel filter may cause poor acceleration of the engine.
- 汽油濾清器因附污過多而不暢通時，會致使引擎轉速難以上升或轉速不穩定。

Maintenance 檢修

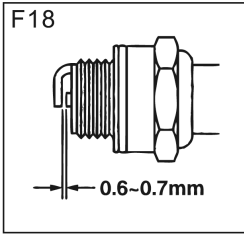

■ SPARK PLUG 火星塞

Starting failure and mis-firing are often caused by a fouled spark plug. Periodically clean the spark plug and replace with a new one as required. The spark gap should be adjusted to 0.6 to 0.7 mm. (F18)

REPLACEMENT PLUG IS A DENSO W-20MU / NGK BM6A.

火星塞堵塞會引起引擎工作不良，請定期清理並適當更換火星塞。卸下火星塞，然後用鋼絲刷清除電極上附著的污垢。電極的間隙 0.6-0.7 mm 為妥。(F18)

更換火星塞時請使用指定產品 DENSO W-20MU / NGK BM6A。

Storage 存放

IMPORTANT 重要

■ MAINTENANCE BEFORE STORAGE 長期存放之前的檢修

Old fuel left in the carburetor may cause starting failure. When a series of operation finished, make sure to empty the fuel tank and run the engine until it uses all the fuel left in the fuel line and the carburetor. Store the unit indoor taking necessary measures for rust prevention.

膜片式引擎:

將燃料箱裡的燃料全部倒出，並啟動引擎，直到其自然熄火停止為止。

浮筒式引擎:

將燃料箱裡的燃料全部倒出，並放鬆化油器的浮子室的排出螺絲或卸油閥以洩出燃料後，要啟動引擎，直到其自然熄火停止為止。

- Check all parts and the functions. If the failed or damaged parts have been found, replace them with new ones.
- 清潔機體的髒污，同時檢查各部位有無損傷或鬆動等。發現有異常時，應該徹底維修調整以備下次使用。

Disposal 廢棄處置

- When disposing your machine, fuel or oil for the machine, be sure to allow your local regulations.
- 丟棄機器、燃料或潤滑油時，請依據並遵守當地相關法規處理。

Specifications 產品規格

NAME 名稱		KNAPSACK POWER SPRAYER 背負式動力噴霧機			
MODEL 型號		HT-708	HT-747	HT-767	HT-768
CHEMICAL TANK CAPACITY 藥桶容量		20 Liter 公升	25 Liter 公升	30 Liter 公升	25 Liter 公升
ENGINE 引擎	ENGINE MODEL 引擎型號	HU-26	HT-328	TB-33	
	CYLINDER DIA./STROKE 汽缸直徑/行程(mm)	33/30	36/30	36/32	
	DISPLACEMENT 排氣量 (C. C.)	25.6	30.5	32.6	
	MAX POWER 最大功率 (HP/7000RPM)	1.4	1.7	1.7	
	CARBURETOR TYPE 化油器型式	FLOAT TYPE / DIAPHRAGM TYPE 浮筒式 / 膜片式			
	IGNITION SYSTEM 磁電機型式	Electronic CDI 電子 CDI			
	SPARK PLUG 火星塞型號	DENSO W-20MU / NGK BM6A			
	FUEL 燃油牌號	Lubricating oil mixed gasoline 90#以上汽油			
	MIXING RATE 燃油、潤滑油容積混合比	WITH 2 STROKE OIL LEVEL FC OR FD 25 : 1 使用市場上銷售的二行程 FC 或 FD 級機油 25 : 1			
	STARTER 啟動方式	STARTER RECOIL 反沖啟動式			
CLUTCH TYPE 動力傳動方式	CENTRIFUGAL TYPE 自動遠心離合器				
PUMP 泵浦	PUMP MODEL 泵浦型號	FTC-16	FTP-21		
	PUMP TYPE 泵浦形式	2-WAY 雙向			
	PLUNGER DIA./STROKE 柱塞直徑/行程	16mm / 9mm		21mm / 6 mm	
	REDUCTION RATIO 減速比	48 : 13		47 : 13	
	MAX. PRESSURE 最大出水壓力	35 kg/cm2 (497.8 psi)			
	MAX. DELIVERY RATE 最大吐油量	8 Liter 公升 / Min.分鐘			



 **弘揚精密實業有限公司**
HIACE ENGINE CO., LTD.

雲林縣莿桐鄉興貴村興中75號
No.75 Singjhong Road, Singguei Village
Cihong Township, Yunlin County, Taiwan
TEL:886-5-5846605 FAX:886-5-5846656
[Http://www.hiace.com.tw](http://www.hiace.com.tw)
E-mail:hiace.engine@msa.hinet.net