

# HIACE ENGINE CO., LTD.

HIACE ENGINE CO., LTD.

## OWNER'S MANUAL

### 使用說明書

#### BRUSH CUTTER 割草機

TL-33 / TB-33

TL-43 / TB-43

TL-52 / TB-52

HT-328 / HT-358

G-35L / G-45L

NB-411

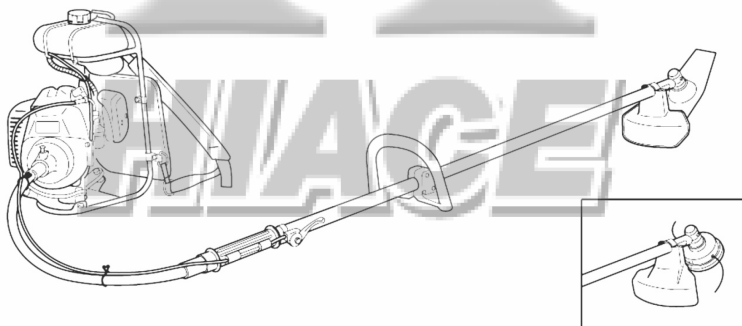

#### CAUTION 注意

- Before using our brush cutter, please read this manual carefully to understand the proper use of your unit.

使用本產品之前請務必先閱讀本使用說明書。

- Keep this manual handy.

本使用說明書請妥善保管。

## Contents 目錄

For safe operation 正確使用須知	1 ~ 3
Set up 安裝	3 ~ 5
Fuel 燃料	6
Use 操作	6 ~ 8
Maintenance 檢修	9 ~ 10
Storage 存放	10
Disposal 廢棄處置	10
Specifications 產品規格	11

## EXPLANATION OF PICTORIALS 警告標籤

- |   |                     |
|---|---------------------|
| (1) Read owners manual before operating the brush cutter.                           | (1) 操作機器前，請閱讀使用說明書。 |
| (2) Wear helmet, eye and ear protection.  | (2) 戴頭盔、防塵眼鏡及耳塞。    |
| (3) Warning / Attention   | (3) 警告 / 注意         |
| (4) Keep all children, bystanders and helpers 15 meters away from the brush cutter. | (4) 15 米以內不得有人      |



(1)

(2)

(3)

(4)

## For safe operation 正確使用須知

- |  |  |
|--|--|
| 1. Read this manual carefully until you completely understand and can follow all safety notes, precautions, and operating instructions before using of the unit.   | 1. 使用前請務必先認真閱讀本使用說明書，將產品的性能及使用上的注意事項理解清楚。  |
| 2. Do not operate this tool when you are tired, ill, or under the influence of alcohol, drugs, or medication.  | 2. 本產品裝有高速旋轉的刀片，如操作失誤將非常危險，故因疲勞等原因身體感到不適時，或由於服用了感冒藥或飲酒後致使判斷能力降低，難以準確進行操作時，請勿使用本產品。 |
| 3. Always wear eye of face protection and hearing protection.  | 3. 操作機器時請務必穿戴適當保護裝備，如防塵眼鏡或臉部防護罩、耳塞...等裝備。  |
| 4. Do not wear loose clothing, jewelry, short trousers, sandals, or go barefoot. Do not wear anything which might be caught by branches or moving parts of the unit. Secure hair so it is above shoulder length. | 4. 操作時請勿穿戴首飾或穿著褲腳寬大的褲子、短褲、涼鞋、草鞋或赤腳。  |
| 5. Never start or run the engine inside a closed room or building. Exhaust gases contain dangerous carbon monoxide.  | 5. 引擎排出的氣體裡含有對人體有害的一氧化碳，請不要在室內、溫室內或隧道內等通風不好的地方使用本產品。                               |

## For safe operation 正確使用須知

- Before starting the engine, inspect the entire unit for loose fasteners and fuel leakage. Make sure that the cutting attachment is properly installed and securely fastened.
- Be sure the cutting attachment guard is firmly attached in place.
- Fuel is highly flammable. Always keep open flames and sparks away from the unit and fuel depot. Do not smoke while refueling the unit or mixing fuel.
- When refueling the unit, make sure to stop the engine and allow it to cool down. Wipe spilled fuel completely from the unit. Move at least 3 meters away from fueling site before starting the engine.
- Check the condition of working area to avoid any accident by hitting hidden obstacles such as stumps, stones, cans, or broken grass.
- Keep bystanders and animals at least 15 meters away from the operating point. If you are approached, immediately stop the engine.
- Keep firm footholds and balance at all times. Do not use the unit where footing is unsteady or slippery.
- Keep cutting attachment below waist level.
- Keep all parts of your body away from rotating cutting attachment and hot surfaces.
- Warn the operator of the danger of blade thrust (Kick back). Blade thrust may occur when the spinning blade contacts a solid object in the critical area. A dangerous reaction may occur causing the entire unit and operator to be thrust violently. This reaction is called Kick back. As a result, the operator can lose control of the unit which can cause serious or fatal injury. Kick back is more likely to occur in areas where it is difficult to see the material to be cut.
- When inspecting or servicing the unit, make sure to stop the engine and disconnect the spark plug as necessary.
- Cover the blade when transporting or storing the unit. Secure the unit before storage or transporting to prevent loss of fuel, damage or injury.
- When replacing cutting attachment or other components, be sure to use the parts supplied or recommended by HIACE.
- When the unit is turned off, make sure the cutting attachment has stopped before the unit is set down.
- For units equipped with a clutch, be sure the cutting attachment stops turning when the engine idles.
- Use only for tasks explained in the instruction handbook.
- 開始作業前，要認真檢查機體各部，在確認沒有螺絲鬆動、漏油、損傷或變形等異常情況後方可開始作業。特別是刀片以及刀片連接部位更要仔細檢查。
- 使用金屬製刀片時，請務必在刀片上安裝附帶的刀片護罩或其它適當的防護罩具。
- 在加油和儲油地區必須嚴禁煙火。禁止叨著香煙作業、加油或混合燃料。
- 在加油之前必須確認引擎停止並冷卻，加油後將燃料容器密封，然後要在離開燃料容器3米以上的地方啟動引擎。
- 在開始作業前，要先弄清現場的狀況（地形、草的性質、障礙物的位置、周圍的危險度等）。清除可以移動的障礙物。
- 以作業者為中心，半徑15米以內為危險區域，為防止他人進入該區域，要用繩索圍起來或立起木牌以示警告，另外幾個人同時工作時，要不時地相互打招呼，並保持安全間隔。
- 割草作業時要保持穩定的姿勢。腳下較滑，難以保持穩定的作業姿態時，請勿使用本產品。
- 操作時請勿將刀片抬高至腰部以上的位置。
- 操作時請勿使刀片靠近操作者的身體。
- 機體反彈是指高速度旋轉的刀片在碰到石塊、樹木、水泥、木樁、支柱等堅硬的固定物體時，由於反作用力，機體在一瞬間劇烈抖動的現象。發生反彈時，機體會突然出現意想不到的振動，有可能致使作業者無法正常操作。
- 需要對刀片、機體進行檢查或維修時，務必先將引擎關閉，讓刀片完全停止轉動後再進行上述作業，如有必要，請卸下火星塞進行檢修。
- 用汽車搬運時，請用繩索將機體牢固的固定在車槽內，以避免機體損壞或燃料外漏，使用金屬製刀片時，請務必在刀片上安裝附帶的刀片護罩或其它適當的防護罩具。因為危險，切勿用自行車或摩托車搬運。
- 刀片等替換用配件，請一定要使用 HIACE 純正產品或 HIACE 所指定的品牌產品。
- 將引擎關閉後，放置機器之前請務必確保刀片已經完全停止轉動。
- 為確保安全，請確認機器在怠速位置時，刀片為停止狀態。
- 請確實依照本說明書的使用事項來操作此機器。

## For safe operation 正確使用須知

22. Discard blades that are bent, warped, cracked, broken or damaged in any way.
23. Instructions on stopping a coasting blade. A blade can injure while it continues to spin after the engine is stopped or throttle control is released.
24. Stop the engine and blade before removing material that is blocking or entangling the cutting attachment.
25. Use a sharp blade. A dull blade is more likely to snag and thrust. Replace the fastening nut according to the manufacturers instruction.
26. Cut only material recommended by HIACE. Do not let the blade contact material it cannot cut, such as rocks, metal etc.
27. Always wear safety boots, additionally a helmet is required if there is a risk of contact with falling objects.
28. Before stopping the engine, be sure the throttle lever was set to the idling position. To stop the running engine at high speeds may cause series damage to engine parts.
22. 確認刀片沒有崩刀、裂口、彎曲之後才能開始使用此機器，絕對不能使用已出現異常的刀片。
23. 中斷作業時，在剛停止引擎或扳回加油柄至無效位置時，高速運轉的刀片在完全停止轉動之前仍然具有殺傷力，請保持安全距離。
24. 需要去除纏繞在刀片上的草，或對刀片、機體進行檢查或加油時，要先將引擎關閉，讓刀片完全停止轉動後再進行上述作業。
25. 刀片請使用研磨好了的、鋒利的。研磨刀片時，為防止刀刀崩裂，一定要把齒根部磨成弧形。
26. 本產品是以割除地表的雜草為目的而設計的，請勿用於其它目的（如用於剪裁樹枝、修剪樹牆、截接，或讓刀片接觸石頭或金屬等禁止接觸材質）。
27. 作業期間請確實穿戴好適當之防護裝備。（如穿防護鞋、戴頭盔、防塵眼鏡及耳塞等。）
28. 關閉引擎前，請確認引擎轉速已降低至怠速，以避免因高速運轉時的急停而對引擎各部造成傷害。

## Set up 安裝

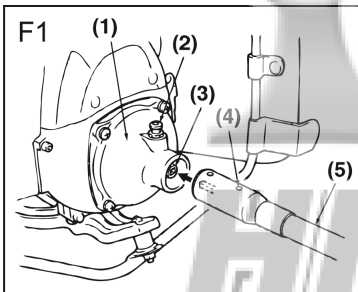

### ENGINE 引擎

- To connect the clutch housing to the liner, lay the liner out straight, align the flexible shaft with the angular hole on the side of the clutch drum, and insert the liner into the clutch housing, being careful to make sure that the hole on the end of the liner is facing directly upwards. When the hole reaches a point directly below the stopper, you will hear a clicking sound as the stopper moves into the hole to fix the liner into place. (F1)
- 將軟管接在離合器上，先將軟管放直，再將軟管軸對準內缸的方孔部，然後將軟管推入離合器外缸。此時，要使軟管的孔朝正上方。拉扣和孔相吻合時會發出喀的聲音，拉扣發生動作，軟管被固定。(F1)

- (1) Clutch housing 離合器外缸 (4) Hole 孔  
 (2) Stopper 拉扣 (5) Liner 軟管  
 (3) Angular hole 內缸方孔部

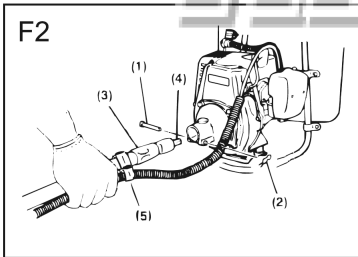

- For HT-328 / HT-358 model: lay the liner out straight, pull out flexible shaft lock pin (1) after removing snap pin (2). Insert flexible shaft (3) into clutch case to the end by inserting square end of flexible inner shaft (4) into square hole of adaptor in clutch case. Put the removed lock pin into the hole of clutch case by engaging the lock pin to the slot of flexible shaft. Replace the snap pin onto the lock pin. (F2)
- HT-328 / HT-358 機型：將軟管放直，取下插銷及 R 扣，軟管軸對準內缸的方孔部，將軟管推入離合器外缸最底部。然後將軟管稍微向外拉，直到插銷可插入外缸及軟管，再將 R 扣插入插銷的孔內固定軟管。安裝完畢再將加油線以固定夾固定在軟管上。(F2)

- (1) Lock Pin 插銷 (4) Inner Shaft 軟管軸心  
 (2) R Snap Pin R 型扣 (5) Clamp 固定夾  
 (3) Shaft 軟管軸

## Set up 安裝

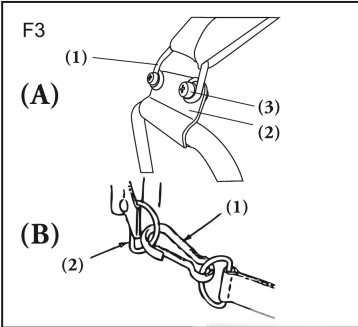

### ■ ATTACHING THE SHOULDER STRAP 安裝背帶

- For HT-328 / HT-358 model: Pass the the shoulder strap into the V type belt buckle, and fix it on the clamp of upper side of flame by the bolt securely. (F3-A)
- HT-328 / HT-358 機型：將二條背帶套入三角金屬扣環內，以附件螺絲將三角金屬扣環套固定在背架上部的固定片上。(F3-A)
- Set the hook of each shoulder strap to the D-rings on the frame. (F3-B)
- 用背帶下部掛鈎鈎住機架下部 D 形環。(F3-B)

#### (A) UPPER SIDE 背架上部：

- (1) V type belt buckle 三角金屬扣環
- (2) Clamp 固定片
- (3) Bolt 螺絲

#### (B) LOWER SIDE 背架下部：

- (1) Hook 掛鈎
- (2) D-ring D 形環

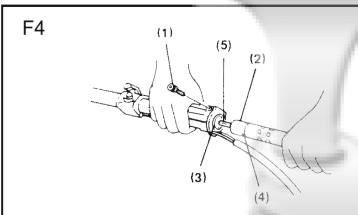

### ■ ATTACHING THE LINER 安裝軟管

- Remove the bolt located on the joint of the outer pipe. (F4)
- Match the groove of the liner with the threaded hole and fix with screw securely. (F4)
- 取下主管側接頭部的調節螺絲。(F4)
- 將軟管的槽對準帶金屬線的孔後用螺絲固定。(F4)

- (1) Bolt 螺絲
- (2) Shaft 軟管軸
- (3) Join Pipe 操作鋁桿
- (4) Groove/Slot 槽
- (5) Inner Shaft 軟管軸心

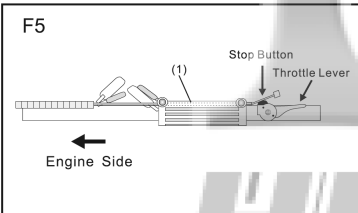

### ■ INSTALLING THROTTLE WIRE AND STOP CORD

#### 安裝加油線及熄火開關

- Put throttle wire and stop switch through cable passage of shaft grip (F5-1). Connect each terminal with each proper position respectively. (F5)
- 將加油線及熄火開關套入繼手膠套內，連接安裝每個接頭於適當位置。(F5)

#### (1) Shaft Grip 繼手膠套

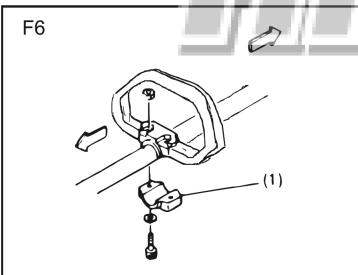

### ■ INSTALLING HANDLE 安裝桃型提把

- Remove the handle bracket. (F6-1)
- Set the handle on, and attach the handle bracket (F6-1) with four screws slightly. And adjust position of the handle according to your working style. Then fix it firmly with the screws. (F6)
- 卸下桃型提把固定座。(F6-1)
- 放置提把至欲安裝位置，輕輕地用四只螺絲稍微固定，然後根據操作者使用習慣適當調整提把位置，調整後再將螺絲鎖緊。(F6)

#### (1) Handle bracket 桃型提把固定座

## Set up 安裝

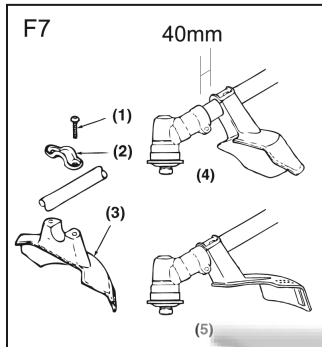

### ■ SAFETY GUARD 擋草盤

- Attach the safety guard to the gear case and fix it with the clamp and 2 bolts securely.(F7)
- 把擋草盤放在齒輪箱前，用擋草盤固定片和 2 個螺絲固定。(F7)

(1) Bolt 螺絲

(2) Clamp 擋草盤固定片

(3) Safety guard 擋草盤

(4) Place to be attached for blade use 使用刀片時之建議位置

(5) Place to be attached for line head 使用尼龍繩時之建議位置

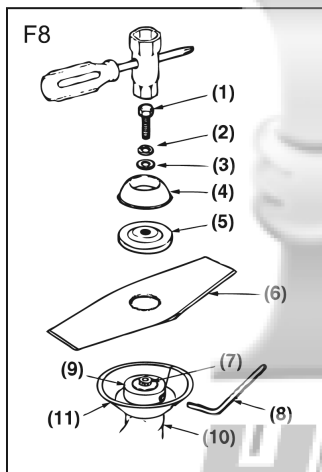

### ■ BLADE 金屬刀片的安裝方法

1. Put the angled bar into the side holes of the inner holder and the gear case.
2. Remove the blade bolt (Left-handed) and the outer holder from the gear shaft.
3. Put the blade onto the inner holder.
4. Put the outer holder onto the gear shaft making the recessed side face the blade.
5. Fasten the blade by the blade bolt with the washers.  
Tightening torque of blade bolt: 15~20 N·m (1.5~2.0 kgm)

1. 請把刀片上壓塊套在齒輪軸上，使用附屬 L 型工具旋轉固定於圓孔內。

2. 取下螺栓(左牙螺帽)和墊圈。

3. 請把刀片有文字的一面放在齒輪箱側的刀片上壓塊上，把刀片孔穴正確的裝在刀片上壓塊的凸部上。

4. 刀片下壓塊凹面向割草刀側，裝在齒輪軸上。

5. 把附屬栓罩放在下壓塊上，請在割草刀片安裝螺栓(左牙螺帽)上放上彈簧墊和平墊圈(或是螺帽)，並確實旋緊。

螺栓(左牙螺帽)的鎖緊扭力: 15~20 N·m (1.5~2.0 kg·m)

(1) Bolt 螺栓(左牙螺帽)

(2) Spring Washer 彈簧墊圈(或是 1+2+3 換為左牙螺帽)

(3) Washer 墊圈

(4) Bolt Cover 螺栓罩

(5) Holder B 下壓塊

(6) Blade 刀片

(7) Gear Shaft 齒軸

(8) L Set Bar L 型工具

(9) Holder A 上壓塊

(10) Gear Case 齒輪箱

(11) Cap for preventing grass from getting caught up 擋草蓋

## Fuel 燃料



### WARNING 警告

- Keep open flames away from the area where fuel is handled or stored.
- Mix and store fuel only in an approved gasoline container.
- 在加油和儲油地區必須嚴禁煙火。
- 請使用適當的容器來混合或儲存燃料。

Mix a regular grade gasoline (leaded or unleaded, alcohol-free) and a quality-proven motor oil for air cooled 2-cycle gasoline engine use.

### Recommended mixing ratio : 25 : 1

建議使用市場上銷售的無鉛汽油及 2 行程 FC 或 FD 級機油。  
建議汽油及機油混合比例：25:1

Mix Chart 混合表

Gasoline (liters) 汽油(公升)	1	2	3	4	5
2-cycle oil (ml.) 二行程機油(毫升 ml.)	40	80	120	160	200

### NOTE 注意

Most engine troubles are caused, directly or indirectly, by the fuel used on the machine. Take special care not to mix a motor oil for 4-cycle engine use.

不能使用 4 衝程引擎，或水冷 2 衝程引擎機油，否則會造成火星塞堵塞，排氣口不通暢，或活塞環障礙。

## Use 操作

### ■ STARTING THE ENGINE 啟動引擎

### WARNING 警告

Take care that the cutting head will start rotating upon the engine starts.

啟動引擎時，刀片會開始旋轉，請注意安全。

1. Open the fuel tank cock. (F9)

2. Move the choke lever to the closed position. (F9)

(1) Fuel cock 燃料開關 (4) Choke lever 阻風拉柄

(2) Close 關閉 (5) Close 關閉

(3) Open 打開 (6) Open 打開

3. Set the throttle lever to the idling position. (F10)

(1) Idling 怠速 (2) Full throttle 全開

4. Place the machine on a flat and firm place, and make sure to keep the blade clear of everything around it. Then, holding the main pipe with your left hand, put your right foot on the frame, and pull out the starter knob with your right hand quickly.

5. After the engine has started, open the choke gradually.

6. Allow the engine to run for 2 to 3 minutes to warm up.

1. 打開燃料箱開關。(F9)

2. 把風門開關移動到關閉位置。(F9)

3. 把油門開關設定在怠速位置。(F10)

4. 將機器放置在平坦堅實的地方，確認刀頭周圍沒有任何物品。

然後左手握住操作桿，右腳踩住背架，用右手快速拉出啟動器拉繩。

5. 在引擎啟動後，漸漸打開風門。

6. 讓引擎轉動 2-3 分鐘預熱。

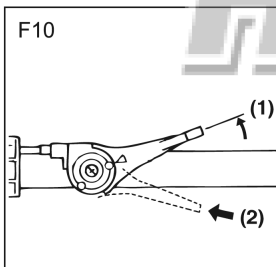
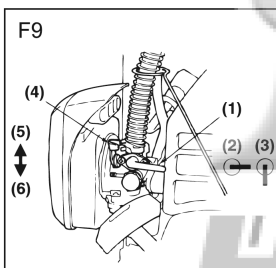

### NOTE 注意

- When restarting immediately after stopping the engine, move the choke lever to the open position, move the throttle lever to the idling position.
- 在引擎停止後馬上重新啟動時，請把風門開關移到打開位置上，把油門開關設定在怠速位置。

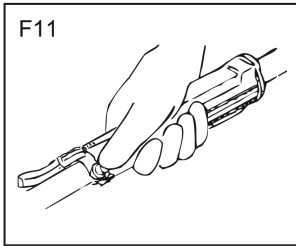

■ STOPPING ENGINE 停止引擎

1. Return the throttle lever to the idling position.
  2. Push the stop button until engine has stopped. Close the fuel cock. (F11)
1. 轉動加油器到怠速位置上。  
2. 按下停止鍵，直到引擎完全停止。關閉燃料開關。(F11)

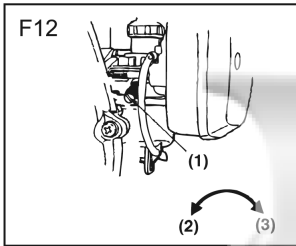

■ ADJUSTING THROTTLE CABLE 調整加油線

The normal play is 1 or 2m when measured at the carburetor side end. Readjust with the cable adjuster as required.

卸下加油器，拉出加油線。從化油器一端丈量的話，一般為 1~2 米長。如果加油線過短或過長，請視需求調整加油線長度。



■ ADJUSTING IDLING SPEED 怠速調整螺絲

It is normal that the engine keeps running without the blade rotation, when the throttle lever is released. When the engine speed is too high or too slow, readjust the idle set screw. (F12)

這是用來調整將加油器扳至「啟動速度」位置時引擎轉數的螺絲。向右(順時針方向)旋轉轉速便會上升，向左(逆時針方向)旋轉轉速便會下降。(F12) 如將加油器扳至「啟動速度」位置時，刀片轉動不停或引擎停止轉動時，可再次調整。

- (1) Idling adjustment screw 怠速調整螺絲
- (2) Rotation increases 轉速增加
- (3) Rotation decreases 轉速降低

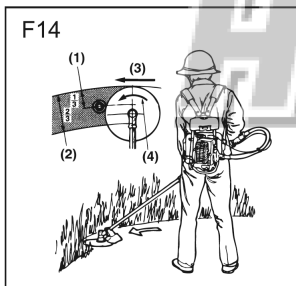

■ Cutting work 割草作業

- By using the shoulder strap, hand the unit on your right side, Adjust the strap length so that the cutting head may become parallel to the ground. (F13, F14)
- 背負方法：右手握住鋁管提把處，將背架左側的背帶揹在左肩上，換左手握住提把，將右側的背帶揹在右肩上。開始作業姿勢時，請調節肩背帶的長度，使割草刀片與地面平行。(F13、F14)



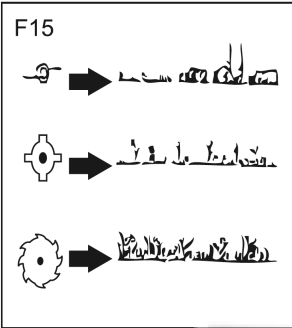

### ■ CUTTING METHOD 割草方式

- Use the front left side for cutting.
  - Guide the blade from your right to left with it tilted slightly to your left.
  - When mowing a wide area, start working from your left end to avoid interference of cut grass.
  - The blade may be seized by weeds if the engine speed is too low, or the blade cuts too deep into weeds. Adjust the engine speed and cutting depth according to the condition of object.
- 切割處為左前方。
  - 割草作業時的動作是從右向左搖晃著機體來進行的。
  - 面對寬闊的割草範圍時，從左端開始割草作業，可避免作業時的干擾。
  - 引擎轉速過低不但容易使草纏卷，還會導致離合器的快速消耗。請根據草的阻力大小隨時調節引擎轉速及切割寬度。

### WARNING 警告

- For your health and to prevent the risk from vibration, refrain from working for a long time at the cold temperature. 請避免在低溫環境下長時間操作機器，以確保操作者的健康及安全。

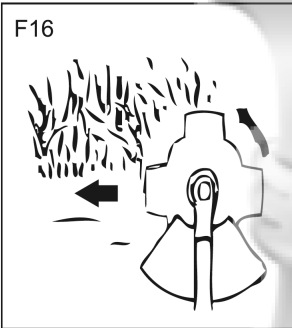

### ■ WHEN USING A METAL BLADE 使用金屬刀片時

- Check the bolt to fasten the blade and be sure the bolt has no fault, and no abrasion.
  - Be sure that the blade and the holder have been fastened according to instruction and the blade turns smoothly without abnormal noise.
  - Guide the blade from your right to left with it tilted slightly to your left. (F16)
- 確認刀頭處之螺栓(左牙螺帽)已安裝適當，且刀片沒有崩刃、裂口、彎曲。
  - 確認刀頭處之壓塊及刀片已依照操作說明安裝好，且刀片轉動時無異常聲響。
  - 割草作業時的動作請從右向左搖晃著機體來進行。(F16)
- The rotating parts fastened incorrectly may cause serious accident to the operator.
  - 刀片以及刀片連接部位要仔細檢查，任何一個零件沒有安裝正確都有可能造成嚴重意外。

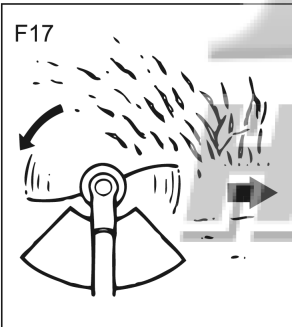

### ■ WHEN USING A NYLON LINE HEAD 使用尼龍繩割草機頭時

- Guide the head from your left to right to let the cut grass be thrown away from you. (F17)
  - Always do cutting with the engine running at full throttle.
  - Use only the tip of the line for cutting, and allow it to trim at its own pace.
- 割草作業時的動作請從左向右搖晃著機體來進行，以避免操作者被割斷的草打傷。(F17)
  - 割草作業時請保持高速位置。
  - 請利用線的頂端來割斷草。

F18

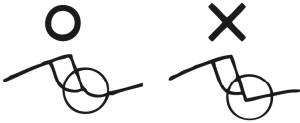

### WARNING 警告

Before cleaning, inspecting, or repairing the unit, make sure that the engine has stopped and is cool.

清理、檢查或修理機器前，先確認引擎已停止並冷卻。

#### ■ BLADE 刀片

- Check the blade and the fasteners for looseness, cracking, or bending.
- Check the cutting edges and reform with a flat file.
- 仔細檢查刀片以及刀片連接部位已安裝適當，沒有螺絲鬆動或損傷的情形。
- 檢查刀刃鋒利程度，適情況使用平坦的銼刀來研磨刀刃。

#### Point (F18) 要點 (F18)

1. Keep the end corner sharp.
2. Round the root of the edge.
3. Do not use water when using a grinder.

1. 刀片請保持鋒利。
2. 研磨刀片時，為防止刀片崩裂，一定要把齒根部磨成弧形。
3. 用研磨機研磨時，刀片會產生高溫，此時如果用水冷卻，有可能發生崩裂，所以應該在空氣中等待其自然冷卻。

#### ■ AIR CLEANER 空氣濾清器

- Check and clean the filter element in warm, soapy water as required. Dry completely before installing. If the element is broken or shrunk, replace with a new one. (F19)
- 請將空氣濾清器的外殼卸下來，清除內部的塵污。濾綿過髒的時候，請用溫水加中性洗滌劑清洗乾淨，待其完全乾燥後重新安裝再用。如濾綿變形或破損，請予以換新。(F19)

#### (1) Element 濾綿

F19

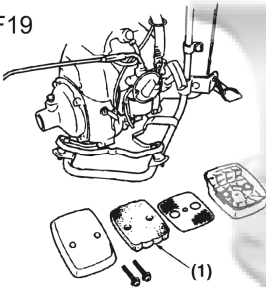

### IMPORTANT 重要

A clogged air filter may increase fuel consumption while cutting down the engine power. And operate the brushcutter without the air filter or with a deformed filter element will quickly ruin the engine.

如果空氣濾清器的濾氣海綿沾污過多而繼續使用時，會使引擎的機能降低。相反，如果不加墊海綿或者使用了變形或破損的海綿，會導致引擎內部異常消耗磨損。

#### ■ FUEL STRAINER 燃料過濾器濾網

- Check how heavily the fuel filter is clogged from the fueling port of the fuel tank every 25 hours of use. If the fuel filter is clogged, please clean the strainer.
- Drain a fuel tank to maintain the strainer. Remove the fuel strainer from fuel pipe and clean sludge from strainer. (F20)
- 每使用約 25 小時後，請從燃料箱的給油口檢查濾網的附污情況。如附污過多時，請清理過濾器濾網。
- 將燃料箱的油全部倒出後，卸下濾網，用刷子刷洗乾淨。無法刷洗乾淨或網膜破損時，請及時換新。(F20)

#### (1) Strainer 濾網

### IMPORTANT 重要

A clogged fuel filter may cause poor acceleration of the engine.

燃料過濾器因附污過多而不暢通時，會致使引擎轉速難以上升或轉速不穩定。

## Maintenance 檢修

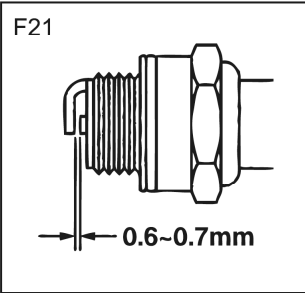

### ■ SPARK PLUG 火星塞

Starting failure and mis-firing are often caused by a fouled spark plug. Periodically clean the spark plug and replace with a new one as required. The spark gap should be adjusted to 0.6 to 0.7 mm. (F21)

**REPLACEMENT PLUG IS A DENSO W-20MU / NGK BM6A.**

火星塞堵塞會引起引擎工作不良，請定期清理並適當更換火星塞。卸下火星塞，然後用鋼絲刷清除電極上附著的污垢。電極的間隙 0.6~0.7 mm 為妥。(F21)

更換火星塞時請使用指定產品 DENSO W-20MU / NGK BM6A。

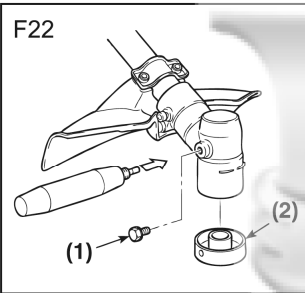

### ■ GEAR CASE 齒輪箱

- Supply HIACE genuine grease at every 25 hours of use.
- Remove the cutter holders to arrange for old grease to exit. (F22)
- 每使用約 25 小時後，要補充齒輪箱內部的潤滑用黃油。
- 卸下刀片、刀片上壓塊及齒輪箱旁邊的螺絲，然後從螺絲孔向裡注入黃油。(F22)

(1) Plug 螺絲 (2) Cutter holder 刀片上壓塊

## Storage 存放

### IMPORTANT 重要

#### ■ MAINTENANCE BEFORE STORAGE 長期存放之前的檢修

Old fuel left in the carburetor may cause starting failure. When a series of operation finished, make sure to empty the fuel tank and run the engine until it uses all the fuel left in the fuel line and the carburetor. Store the unit indoor taking necessary measures for rust prevention.

將燃料箱裡的燃料全部倒出，並放鬆化油器的浮子室的排出螺絲或卸油閥以洩出燃料後，要啟動引擎，直到其自然熄火停止為止。

- Check all parts and the functions. If the failed or damaged parts have been found, replace them with new ones.
- 清潔機體的髒污，同時檢查各部位有無損傷或鬆動等。發現有異常時，應該徹底維修調整以備下次使用。

## Disposal 廢棄處置

- When disposing your machine, fuel or oil for the machine, be sure to allow your local regulations.
- 丟棄機器、燃料或潤滑油時，請依據並遵守當地相關法規處理。

## Specifications 產品規格

NAME 名稱		KNAPSACK TYPE BRUSH CUTTER 背負式割草機							
MODEL 型號		TL-33 / TB-33	TL-43 / TB-43	TL-52 / TB-52	HT-328	HT-358	G-35L	G-45L	NB-411
HANDLE TYPE 手把型式		LOOP TYPE 桃型提把							
ENGINE 引擎	CYLINDER DIAMETER (mm) 汽缸直徑(mm)	36	40	44	36	38	36	40	40
	PISTON STROKE (mm) 活塞行程 (mm)	32	34	34	30	30	32	32	32
	DISPLACEMENT (C.C.) 排氣量 (C. C.)	32.6	42.7	51.7	30.5	34	32.6	41.5	40.2
	MAX POWER 最大功率 (HP/7000RPM)	1.7	2.1	2.3	1.7	1.9	1.7	2.2	2.0
	CARBURETOR TYPE 化油器型式	FLOAT TYPE 浮筒式							
	IGNITION SYSTEM 磁電機型式	Electronic CDI 電子 CDI							
	SPARK PLUG 火星塞型號	DENSO W-20MU / NGK BM6A							
	FUEL 燃油牌號	Lubricating oil mixed gasoline 90#以上汽油							
	MIXING RATE 燃油、潤滑油容積混合比	WITH 2 STROKE OIL LEVEL FC OR FD 25 : 1 使用市場上銷售的二行程 FC 或 FD 級機油 25 : 1							
	FUEL TANK CAPACITY(L) 燃油箱容積 (L)	1.3							0.8
	STARTER 啟動方式	STARTER RECOIL 反沖啟動式							
CLUTCH TYPE 動力傳動方式	CENTRIFUGAL TYPE 自動遠心離合器、螺旋錐齒輪								
REDUCTION RATIO 減速比	Φ26MM : 1.25 / Φ26MM : 1.29								

# HIACE



 弘揚精密實業有限公司  
HIACE ENGINE CO., LTD.

雲林縣莿桐鄉興貴村興中75號  
No.75 Singjhong Road, Singguei Village  
Cihdong Township, Yunlin County, Taiwan  
TEL:886-5-5846605 FAX:886-5-5846656  
[Http://www.hiace.com.tw](http://www.hiace.com.tw)  
E-mail:[hiace.engine@msa.hinet.net](mailto:hiace.engine@msa.hinet.net)