

HIACE ENGINE CO., LTD.

OWNER'S MANUAL

BRUSH CUTTER

HU-26L

HT-328L/358L

TL-33L/43L/52L

TB-33L/43L/52L



CAUTION 注意

- Before using our brush cutter, please read this manual carefully to understand the proper use of your unit.
使用本產品之前請務必先閱讀本使用說明書。
- Keep this manual handy. 本使用說明書請妥善保管。

Contents 目錄

For safe operation 正確使用須知.....	2~4
Set up 安裝.....	4~5
Fuel 燃料.....	6
Use 操作.....	6~8
Maintenance 檢修.....	9~10
Storage 存放.....	10
Disposal 廢棄處置.....	10
Specifications 產品規格.....	11

EXPLANATION OF PICTORIALS 警告標籤

- | | |
|---|---------------------|
| (1) Read owner's manual before operating the brush cutter. | (1) 操作機器前，請閱讀使用說明書。 |
| (2) Wear helmet, eye and ear protection. | (2) 戴頭盔、防塵眼鏡及耳塞。 |
| (3) Warning / Attention | (3) 警告 / 注意 |
| (4) Keep all children, bystanders and helpers 15 meters away from the brush cutter. | (4) 15 米以內不得有人 |

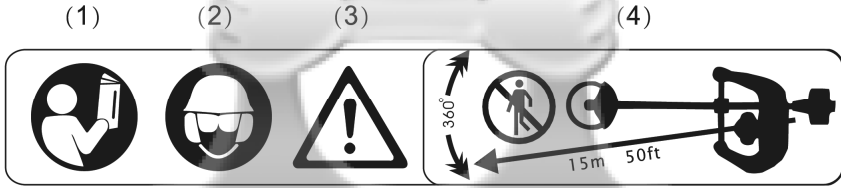

For safe operation 正確使用須知

- | | |
|--|--|
| 1. Read this manual carefully until you completely understand and can follow all safety notes, precautions, and operating instructions before using of the unit. | 1. 使用前請務必先認真閱讀本使用說明書，將產品的性能及使用上的注意事項理解清楚。 |
| 2. Do not operate this tool when you are tired, ill, or under the influence of alcohol, drugs, or medication. | 2. 本產品裝有高速旋轉的刀片，如操作失誤將非常危險，故因疲勞等原因身體感到不適時，或由於服用了感冒藥或飲酒後致使判斷能力降低，難以準確進行操作時，請勿使用本產品。 |
| 3. Always wear eye of face protection and hearing protection. | 3. 操作機器時請務必穿戴適當保護裝備，如防塵眼鏡或臉部防護罩、耳塞...等裝備。 |
| 4. Do not wear loose clothing, jewelry, short trousers, sandals, or go barefoot. Do not wear anything which might be caught by branches or moving parts of the unit. Secure hair so it is above shoulder length. | 4. 操作時請勿穿戴首飾或穿著褲腳寬大的褲子、短褲、涼鞋、草鞋或赤腳。 |
| 5. Never start or run the engine inside a closed room or building. Exhaust gases contain dangerous carbon monoxide. | 5. 引擎排出的氣體裡含有對人體有害的一氧化碳，請不要在室內，溫室內或隧道內等通風不好的地方使用本產品。 |

For safe operation 正確使用須知

- Before starting the engine, inspect the entire unit for loose fasteners and fuel leakage. Make sure that the cutting attachment is properly installed and securely fastened.
- Be sure the cutting attachment guard is firmly attached in place.
- Fuel is highly flammable. Always keep open flames and sparks away from the unit and fuel depot. Do not smoke while refueling the unit or mixing fuel.
- When refueling the unit, make sure to stop the engine and allow it to cool down. Wipe spilled fuel completely from the unit. Move at least 3 meters away from fueling site before starting the engine.
- Check the condition of working area to avoid any accident by hitting hidden obstacles such as stumps, stones, cans, or broken grass.
- Keep bystanders and animals at least 15 meters away from the operating point. If you are approached, immediately stop the engine.
- Keep firm footholds and balance at all times. Do not use the unit where footing is unsteady or slippery.
- Keep cutting attachment below waist level.
- Keep all parts of your body away from rotating cutting attachment and hot surfaces.
- Warn the operator of the danger of blade thrust (Kick back). Blade thrust may occur when the spinning blade contacts a solid object in the critical area. A dangerous reaction may occur causing the entire unit and operator to be thrust violently. This reaction is called Kick back. As a result, the operator can lose control of the unit which can cause serious or fatal injury. Kick back is more likely to occur in areas where it is difficult to see the material to be cut.
- When inspecting or servicing the unit, make sure to stop the engine and disconnect the spark plug as necessary.
- Cover the blade when transporting or storing the unit. Secure the unit before storage or transporting to prevent loss of fuel, damage or injury.
- When replacing cutting attachment or other components, be sure to use the parts supplied or recommended by HIACE.
- When the unit is turned off, make sure the cutting attachment has stopped before the unit is set down.
- For units equipped with a clutch, be sure the cutting attachment stops turning when the engine idles.
- Use only for tasks explained in the instruction handbook.
- 開始作業前，要認真檢查機體各部，在確認沒有螺絲鬆動、漏油、特別是在刀片連接部位更要仔細檢查。
- 使用金屬製刀片時，請務必在刀片上安裝附帶的刀片護罩或其它適當的防護罩具。
- 在加油和儲油地區必須嚴禁煙火。禁止叨著香煙作業、加油或混合燃料。
- 在加油之前必須確認引擎停止並冷卻，加油後將燃料容器密封，然後要在離開燃料容器 3 米以上的地方啟動引擎。
- 在開始作業前，要先弄清現場的狀況（地形、草的性質、障礙物的位置、周圍的危險度等）。清除可以移動的障礙物。
- 以作業者為中心，半徑 15 米以內為危險區域，為防止他人進入該區域，要用繩索圍起來或立起木牌以示警告，另外幾個人同時工作時，要不時地相互打招呼，並保持安全間隔。
- 割草作業時要保持穩定的姿勢。腳下較滑，難以保持穩定的作業姿態時，請勿使用本產品。
- 操作時請勿將刀片抬高至腰部以上的位置。
- 操作時請勿使刀片靠近操作者的身體。
- 機體反彈是指高速度旋轉的刀片在碰到石塊、樹木、水泥、木樁、支柱等堅硬的固定物體時，由於反作用力，機體在一瞬間劇烈抖動的現象。發生反彈時，機體會突然出現意想不到的振動，有可能致使作業者無法正常操作。
- 需要對刀片、機體進行檢查或維修時，務必先將引擎關閉，讓刀片完全停止轉動後再進行上述作業，如有必要，請卸下火星塞進行檢修。
- 用汽車搬運時，請用繩索將機體牢固的固定在車槽內，以避免機體損壞或燃料外漏，使用金屬製刀片時，請務必在刀片上安裝附帶的刀片護罩或其它適當的防護罩具。因為危險，切勿用自行車或摩托車搬運。
- 刀片等替換用配件，請一定要使用 HIACE 純正產品或 HIACE 所指定的品牌產品。
- 將引擎關閉後，放置機器之前請務必確保刀片已經完全停止轉動。
- 為確保安全，請確認機器在怠速位置時，刀片為停止狀態。
- 請確實依照本說明書的使用事項來操作此機器。

For safe operation 正確使用須知

22. Discard blades that are bent, warped, cracked, broken or damaged in any way.
23. Instructions on stopping a coasting blade. A blade can injure while it continues to spin after the engine is stopped or throttle control is released.
24. Stop the engine and blade before removing material that is blocking or entangling the cutting attachment.
25. Use a sharp blade. A dull blade is more likely to snag and thrust. Replace the fastening nut according to the manufacturer's instruction.
26. Cut only material recommended by HIACE. Do not let the blade contact material it cannot cut, such as rocks, metal etc.
27. Always wear safety boots, additionally a helmet is required if there is a risk of contact with falling objects.
28. Before stopping the engine, be sure the throttle lever was set to the idling position. To stop the running engine at high speeds may cause series damage to engine parts.
22. 確認刀片沒有崩裂、裂口、彎曲之後才出
能開始使用此刀片。
23. 中斷作業時，在停止引擎或扳回刀片後，
至無轉距。置之前，仍須待引擎完全
全停止。在檢查刀片上的油泥，
持安全去機。繞行刀片，要對刀片
需片上、關機。讓業。用研磨好的、鋒的。研磨
上片部請時磨。防形。刀刀崩裂，一定把齒
24. 本產品是以割除表目的雜草為目的而設
計的樹枝，或修樹等。其接觸材料（如讓
石頭、金屬等）禁止接觸。
25. 作業期間，請確實穿戴好適當之防護裝
備。（如穿耳塞等。）
26. 關閉引擎前，請確認引擎轉速已降低
至怠速，以避免因高速運轉時的急
而對引擎各部造成傷害。

Set up 安裝

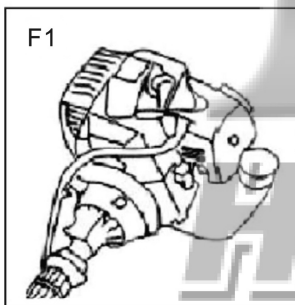

ENGINE 引擎

- Using attached 4 bolts, secure the connection firmly with equal force. (F1)
- 將操作桿以附屬 4 只螺絲，連接引擎。(F1)

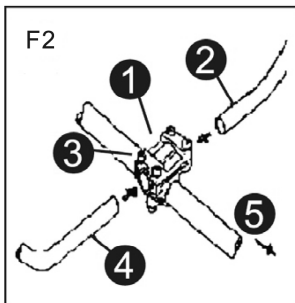

INSTALLING HANDLE 安裝把手

- Loosen the 4 bolts on the handle bracket. (F2)
- Insert the right handle (throttle lever is attached) and the left handle assembly into the bracket and retighten the bolts securely. (F2)
- 鬆開把手固定座組上的螺絲。(F2)
- 插入右把手（附帶加油器），再將左把手也插入把手座組，然後鎖緊螺絲固定把手。(F2)

- Handle bracket 把手固定座組
- Right handle 右把手
- Bolt 螺絲
- Left handle 左把手
- Engine side 引擎端

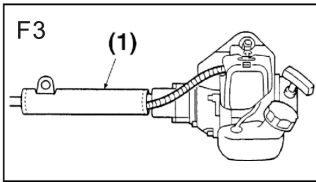

■ **PROTECTOR 護腰墊**

- Wrap the protector around the outer pipe as shown in the figure. (F3).
- 依附圖在鋁管上裝上護腰墊。

(1) Protector 護腰墊

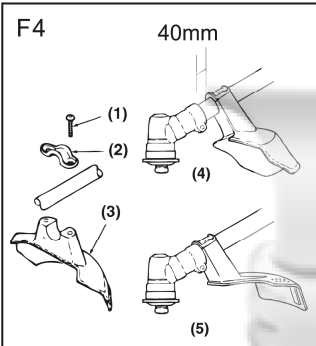

■ **SAFETY GUARD 擋草盤**

- Attach the safety guard to the gear case and fix it with the clamp and 2 bolts securely.(F4)
- 把擋草盤放在齒輪箱前，用擋草盤固定片和 2 個螺絲固定。(F4)

- (1) Bolt 螺絲
- (2) Clamp 擋草盤固定片
- (3) Safety guard 擋草盤
- (4) Place to be attached for blade use 使用刀片時之建議位置
- (5) Place to be attached for line head 使用尼龍繩時之建議位置

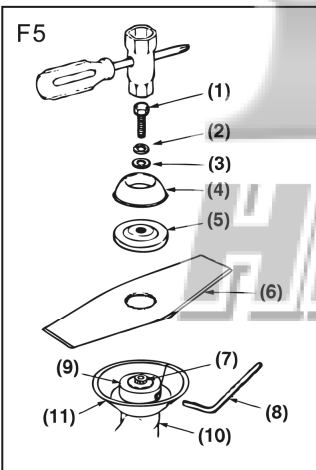

■ **BLADE 金屬刀片的安裝方法**

1. Put the angled bar into the side holes of the inner holder and the gear case. (F5)
2. Remove the blade bolt (Left-handed) and the outer holder from the gear shaft.
3. Put the blade onto the inner holder.
4. Put the outer holder onto the gear shaft making the recessed side face the blade.
5. Fasten the blade by the blade bolt with the washers. Tightening torque of blade bolt: 15~20 N·m (1.5~2.0 kg · m)

1. 請把刀片上壓塊套在齒輪軸上，使用附屬 L 型工具旋轉固定於圓孔內。(F5)
 2. 取下螺栓(左牙螺帽)和墊圈。
 3. 請把刀片有文字的一面放在齒輪箱側的刀片上壓塊上，把刀片孔穴正確的裝在刀片上壓塊的凸部上。
 4. 刀片下壓塊凹面向割草刀側，裝在齒輪軸上。
 5. 把附屬控草放在下壓塊上，請在割草刀片安裝螺栓(左牙螺帽)上放上彈簧墊和平墊圈(或是螺帽)，並確實旋緊。
- 螺栓(左牙螺帽)的鎖緊扭力: 15~20 N·m (1.5~2.0 kg · m)

- (1) Bolt 螺栓(左牙螺帽)
- (2) Spring Washer 彈簧墊圈(或是 1+2+3 換為左牙螺帽)
- (3) Washer 墊圈
- (4) Bolt Cover 螺栓罩
- (5) Holder B 下壓塊
- (6) Blade 刀片
- (7) Gear Shaft 齒軸
- (8) L Set Bar L 型工具
- (9) Holder A 上壓塊
- (10) Gear Case 齒輪箱
- (11) Cap for preventing grass from getting caught up 擋草蓋

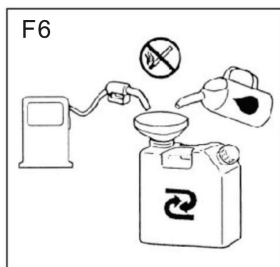

WARNING 警告

- Keep open flames away from the area where fuel is handled or stored.
- Mix and store fuel only in an approved gasoline container.
- 在加油和儲油地區必須嚴禁煙火。
- 請使用適當的容器來混合或儲存燃料。

Mix a regular grade gasoline (leaded or unleaded, alcohol-free) and a quality-proven motor oil for air cooled 2-cycle gasoline engine use. (F6)
 建議使用市場上銷售的無鉛汽油及 2 行程 FC 或 FD 級機油。(F6)
Recommended mixing ratio 建議汽油及機油混合比例：25: 1

Mix Chart 混合表					
Gasoline (liters) 汽油(公升)	1	2	3	4	5
2-cycle oil (ml.) 二行程機油(毫升 ml.)	40	80	120	160	200

NOTE 注意

Most engine troubles are caused, directly or indirectly, by the fuel used on the machine. Take special care not to mix a motor oil for 4-cycle engine use.

不能使用 4 衝程引擎，或水冷 2 衝程引擎機油，否則會造成火星塞堵塞，排氣口不通暢，或活塞環障礙。

Use 操作

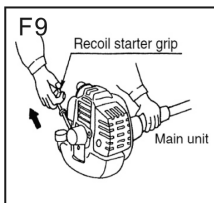
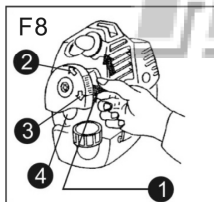
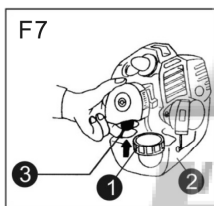

STARTING THE ENGINE 啟動引擎

WARNING 警告

Take care that the cutting head will start rotating upon the engine starts.
 啟動引擎時，刀片會開始旋轉，請注意安全。

1. Move the engine switch to the "ON" position.
 2. Set the throttle lever at the slow speed position.
 3. Push the priming button repeatedly with finger till it hits the top. (More than 10 times) (F7)
 - ◆ Pressing the priming button is necessary to prime the fuel to facilitate the start-up. Since any excess amount of primed fuel returns to the tank, there is no problem of over-priming. Prime the fuel rather more than sufficiently to avoid starting trouble.
 4. Turn the choke lever to the fully closed position. (F8)
 - ◆ When sufficient fuel is retained and the engine is warm, set the choke lever at the fully opened position.
 5. While holding down the engine firmly, grasp the recoil starter grip and pull vigorously. (F9)
 6. When the engine has started, return the choke lever gradually to the fully opened position.
 - ◆ If only exploding sounds are heard but it does not start, return the choke lever to the fully closed position
1. 將引擎開關設定至"ON"位置。
 2. 把油門開關設定在怠速位置。
 3. 按壓化油器下方的汽油泵數次，直到汽油泵內充滿汽油。(F7)
 4. 把風門開關移動到關閉位置。(F8)
 5. 將機器放置在平坦堅實的地方，確認刀頭周圍沒有任何物品。然後左手握住操作桿，右腳踩住背架，用右手快速拉出啟動器拉繩。(F9)
 6. 在引擎啟動後，漸漸打開風門。讓引擎轉動 2~3 分鐘預熱後即可使用。

■ STOPPING ENGINE 停止引擎

1. Release the throttle lever.
2. Move the engine switch to the "STOP" position.
(Switch position may vary depending on the specifications. Refer to the instruction manual of driven equipment.)
 - ◆ In case of a push button type switch, keep pressing the push button till the engine stops completely.
 - ◆ Replenish the fuel before using up completely. It will make easier at the next starting.
 - ◆ When there is no subsequent work, drain the fuel from the fuel tank and restart the engine to use up the fuel remaining in the carburetor.

1. 轉動加油器到怠速位置上。
2. 移動引擎開關至停止位置，直到引擎完全停止。關閉燃料開關。
 - ◆ 如為按壓式停止開關，請持續按壓停止開關直到引擎完全停止。
 - ◆ 為使下次啟動更容易，建議燃料使用完畢再添加新的燃料。
 - ◆ 如有一段時間未使用到本機器，請將燃料全部洩出，再啟動引擎，直到其自然熄火停止為止。

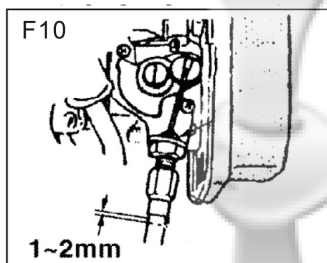

■ ADJUSTING THROTTLE CABLE 調整加油線

The normal play is 1 or 2mm when measured at the carburetor side end. Readjust with the cable adjuster as required. (F10)

卸下加油器，拉出加油線。從化油器一端量量的話，一般為1-2毫米長。如果加油線過短或過長，請視需求調整加油線長度。(F10)

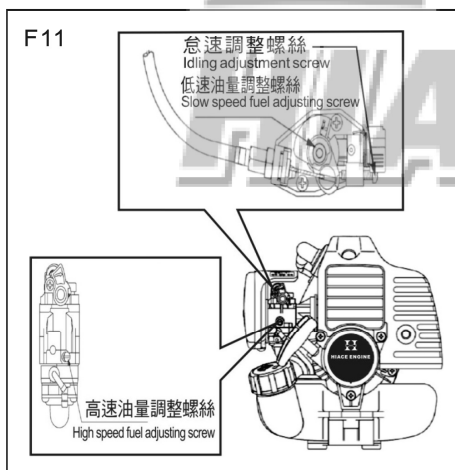

■ ADJUSTING IDLING SPEED 怠速調整螺絲

It is normal that the engine keeps running without the blade rotation, when the throttle lever is released. When the engine speed is too high or too slow, readjust the idle set screw. (F11)

這是用來調整將加油器扳至「啟動速度」位置時引擎轉數的螺絲。向右(順時針方向)旋轉時轉速便會上升，向左(逆時針方向)旋轉時轉速便會下降。如將加油器扳至「啟動速度」位置時，刀片轉動不停或引擎停止轉動時，可再次調整。(F11)

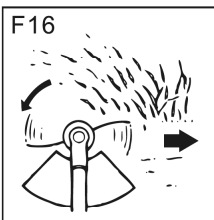
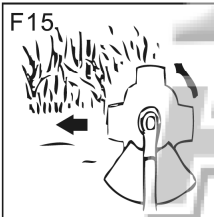
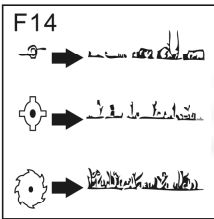
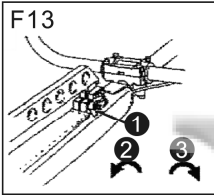

■ CUTTING WORK 割草作業

- By using the shoulder strap, hand the unit on your right side, Adjust the strap length so that the cutting head may become parallel to the ground. (F12)
- 啟動引擎，把加油器退回到怠速位置，然後，把肩帶的掛鈎扣在機體的吊環上，將背帶挎在右肩上。開始作業時，請調節肩背帶的長度，使割刀與地面平行，為了防止作業中鬆緩，請將肩背帶的多餘部分外部折回到扣環處。(F12)

■ SWIVEL LOCK 轉動鎖 (Optional 選配)

- a) When the unit is not hung down with the harness, as in transportation, use the swivel lock to prevent the engine from roll down.
 - b) To lock the swivel, turn the wing nut (F13-1) clockwise (F13-3).
 - c) For normal operation, keep the wing nut loose (F13-2).
- a) 本割草機備有可以使背帶吊架和鋁管固定在任意位置上的轉動鎖機構。搬運時等，需要固定鋁管，請旋緊蝶形螺絲。
 - b) 欲啟動轉動鎖，請以順時針方向(F13-3)旋緊蝶形螺絲(F13-1)。
 - c) 通常作業時，請將背帶吊架前部的蝶形螺絲呈鬆動(解除鎖)狀態使用。(F13-2)

■ CUTTING METHOD 割草方式

- a) Use the front left side for cutting.
 - b) Guide the blade from your right to left with it tilted slightly to your left.
 - c) When mowing a wide area, start working from your left end to avoid interference of cut grass.
 - d) The blade may be seized by weeds if the engine speed is too low, or the blade cuts too deep into weeds. Adjust the engine speed and cutting depth according to the condition of object. (F14)
- a) 切割處為左前方。
 - b) 割草作業時的動作是從右向左搖晃著機體來進行的。
 - c) 面對寬闊的割草範圍時，從左端開始割草作業，可避免作業時的干擾。
 - d) 引擎轉速過低不但容易使草纏卷，還會導致離合器的快速消耗。請根據草的阻力大小隨時調節引擎轉速及切割寬度。(F14)

■ WHEN USING A METAL BLADE 使用金屬刀片時

1. Check the bolt to fasten the blade and be sure the bolt has no fault, and no abrasion.
 2. Be sure that the blade and the holder have been fastened according to instruction and the blade turns smoothly without abnormal noise.
 3. Guide the blade from your right to left with it tilted slightly to your left. (F15)
1. 確認刀頭處之螺栓(左牙螺帽)已安裝適當，且刀片沒有崩刃、裂口、彎曲。
 2. 確認刀頭處之壓塊及刀片已依照操作說明安裝好，且刀片轉動時無異常聲響。
 3. 割草作業時的動作請從右向左搖晃著機體來進行。(F15)
- The rotating parts fastened incorrectly may cause serious accident to the operator.
 - 刀片以及刀片連接部位要仔細檢查，任何一個零件沒有安裝正確都有可能造成嚴重意外。

■ WHEN USING A NYLON LINE HEAD 使用尼龍繩割草機頭時

1. Guide the head from your left to right to let the cut grass be thrown away from you. (F16)
 2. Always do cutting with the engine running at full throttle.
 3. Use only the tip of the line for cutting, and allow it to trim at its own pace.
1. 割草作業時的動作請從左向右搖晃著機體來進行，以避免操作者被割斷的草打傷。(F16)
 2. 割草作業時請保持高速位置。
 3. 請利用線的頂端來割斷草。
- For your health and to prevent the risk from vibration, refrain from working for a long time at the cold temperature
 - 請避免在低溫環境下長時間操作機器，以確保操作者的健康及安全。

WARNING 警告

Before cleaning, inspecting, or repairing the unit, make sure that the engine has stopped and is cool.
清理、檢查或修理機器前，先確認引擎已停止並冷卻。

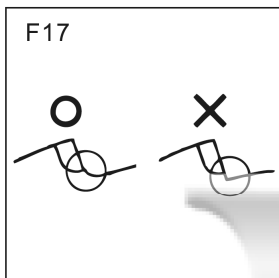

■ BLADE 刀片

- Check the blade and the fasteners for looseness, cracking, or bending.
- Check the cutting edges and reform with a flat file.
- 仔細檢查刀片以及刀片連接部位已安裝適當，沒有螺絲鬆動或損傷的情形。
- 檢查刀片鋒利程度，適情況使用平坦的銼刀來研磨刀片。

Point (F17) 要點 (F17)

1. Keep the end corner sharp.
2. Round the root of the edge.
3. Do not use water when using a grinder.

1. 刀片請保持鋒利。
2. 研磨刀片時，為防止刀片崩裂，一定要把齒根部磨成弧形。
3. 用研磨機研磨時，刀片會產生高溫，此時如果用水冷卻，有可能發生崩裂，所以應該在空氣中等待其自然冷卻。

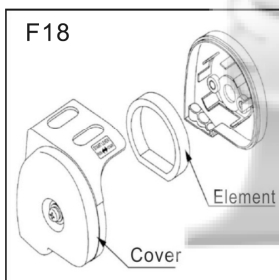

■ AIR CLEANER 空氣濾清器

- Check and clean the filter element in warm, soapy water as required. Dry completely before installing. If the element is broken or shrunk, replace with a new one. (F18)
 - 請將空氣濾清器的外殼卸下來，清除內部的塵污。濾綿過髒的時候，請用溫水加中性洗滌劑清洗乾淨，待其完全乾燥後重新安裝再用。如濾綿變形或破損，請予以換新。(F18)
- (1) Element 濾綿 (2) Cover 空氣濾清器外蓋

IMPORTANT 重要

A clogged air filter may increase fuel consumption while cutting down the engine power. And operate the brushcutter without the air filter or with a deformed filter element will quickly ruin the engine.

如果空氣濾清器的濾氣海綿沾污過多而繼續使用時，會使引擎的機能降低。相反，如果不加墊海綿或者使用了變形或破損的海綿，會導致引擎內部異常消耗磨損。

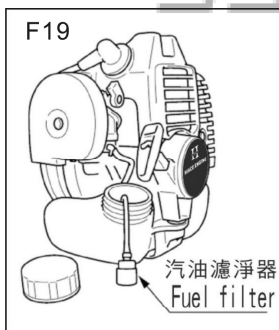

■ FUEL FILTER 汽油濾清器

- After every 25 hours of operation, empty the fuel tank, detach the fuel filter from the tank, and remove all dirt. If the filter is too clogged, please replace it with a new one. (F19)
- 要從燃料箱的給油口對汽油濾清器進行檢查，如附污過多時，請將燃料箱的油全部倒出後，將汽油濾清器卸下並清除髒污，如汽油濾清器附污過多，請及時換新。(F19)

IMPORTANT

- A clogged fuel filter may cause poor acceleration of the engine.
- 汽油濾清器因附污過多而不暢通時，會致使引擎轉速難以上升或轉速不穩定。

Maintenance 檢修

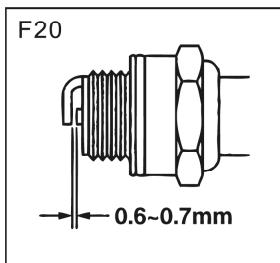

■ SPARK PLUG 火星塞

Starting failure and mis-firing are often caused by a fouled spark plug. Periodically clean the spark plug and replace with a new one as required. The spark gap should be adjusted to 0.6 to 0.7 mm. (F20)

REPLACEMENT PLUG IS A DENSO W-20MU / NGK BM6A.

火星塞堵塞會引起引擎工作不良，請定期清理並適當更換火星塞。卸下火星塞，然後用鋼絲刷清除電極上附著的污垢。電極的間隙 0.6-0.7 mm 為妥。(F20)

更換火星塞時請使用指定產品 DENSO W-20MU / NGK BM6A。

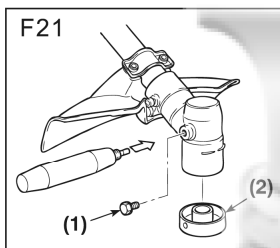

■ GEAR CASE 齒輪箱

- Supply HIACE genuine grease at every 25 hours of use.
- Remove the cutter holders to arrange for old grease to exit. (F21)
- 每使用約 25 小時後，要補充齒輪箱內部的潤滑用黃油。
- 卸下刀片、刀片上壓塊及齒輪箱旁邊的螺絲，然後從螺絲孔向裡注入黃油。(F21)

(1) Plug 螺絲 (2) Cutter holder 刀片上壓塊

Storage 存放

IMPORTANT 重要

■ MAINTENANCE BEFORE STORAGE 長期存放之前的檢修

Old fuel left in the carburetor may cause starting failure. When a series of operation finished, make sure to empty the fuel tank and run the engine until it uses all the fuel left in the fuel line and the carburetor. Store the unit indoor taking necessary measures for rust prevention.

將燃料箱裡的燃料全部倒出，並啟動引擎，直到其自然熄火停止為止。

- Check all parts and the functions. If the failed or damaged parts have been found, replace them with new ones.
- 清潔機體的髒污，同時檢查各部位有無損傷或鬆動等。發現有異常時，應該徹底維修調整以備下次使用。

Disposal 廢棄處置

- When disposing your machine, fuel or oil for the machine, be sure to allow your local regulations.
- 丟棄機器、燃料或潤滑油時，請依據並遵守當地相關法規處理。

Specifications 產品規格

NAME 名稱		SHOULDER TYPE BRUSH CUTTER 肩掛式割草機					
MODEL 型號		HU-26L	HT-328L	HT-358L	TL-33L/ TB-33L	TL-43L/ TB-43L	TL-52L/ TB-52L
HANDLE TYPE 手把型式		U TYPE / LOOP HANDLE U 型提把 / 桃型提把					
ENGINE 引擎	CYLINDER DIAMETER (mm) 汽缸直徑(mm)	33	36	38	36	40	44
	PISTON STROKE (mm) 活塞行程 (mm)	30	30	30	32	34	34
	DISPLACEMENT (C.C.) 排氣量 (C.C.)	25.6	30.5	34	32.6	42.7	51.7
	MAX POWER 最大功率 (HP/7000RPM)	1.4	1.7	1.9	1.7	2.1	2.3
	CARBURETOR TYPE 化油器型式	DIAPHRAGM TYPE 膜片式					
	IGNITION SYSTEM 磁電機型式	Electronic CDI 電子 CDI					
	SPARK PLUG 火星塞型號	DENSO W-20MU / NGK BM6A					
	FUEL 燃油牌號	Lubricating oil mixed gasoline 90#以上汽油					
	MIXING RATE 燃油、潤滑油容積混合比	WITH 2 STROKE OIL LEVEL FC OR FD 25 : 1 使用市場上銷售的二行程 FC 或 FD 級機油 25 : 1					
	FUEL TANK CAPACITY(L) 燃油箱容積 (L)	1 Liter 1 公升					
	STARTER 啟動方式	STARTER RECOIL 反沖啟動式					
	CLUTCH TYPE 動力傳動方式	CENTRIFUGAL TYPE 自動遠心離合器、螺旋錐齒輪					
REDUCTION RATIO 減速比	Φ24MM : 1.267 / Φ26MM : 1.25 / Φ28MM : 1.333						



 弘揚精密實業有限公司
HIACE ENGINE CO., LTD.

雲林縣莿桐鄉興貴村興中75號
No.75 Singjhong Road, Singguei Village
Cihdong Township, Yunlin County, Taiwan
TEL:886-5-5846605 FAX:886-5-5846656
[Http://www.hiace.com.tw](http://www.hiace.com.tw)
E-mail:hiace.engine@msa.hinet.net